

CONTENS

■ BEFORE OPERATING	PAGE
○Lubrication	1
○Manual lubrication	2
○Filling the HR device with silicon oil	3
○Threading	4
○Threading diagram (2-needle/3-needle/4-needle)	5
■ TEST SEWING	
○Presser foot pressure	6
○Diff.feed ratio	7
○Stitch length	8
○Thread tention	9
■ MAINTENANCE DURING USE	
○Cleaning the maching	10
○Replacing the needle	11
○Checking the oil circulation	12
○Checking and replaceing the oil filter	13
○Replaceing the oil	14
○Adjustment Dimensions	15
○Adjustment Dimensions	16-28

INTRODUCTION

Thank you very much for purchasing 500 Series machine.

This instruction manual describes daily routine maintenance and safety precautions to keep the machine in the best possible conditions.

Please study this manual very carefully before operating the machine.



CAUTION

OBSERVE THESE SAFETY PRECAUTIONS

Though Sewing Machine takes the utmost care to produce safe sewing machines and devices, operators should follow these basic safety rules.

- To prevent accidents, do not remove safety devices or parts while operating the machine.
- Do not leave tools or other unnecessary objects on the machine table while operating the machine.
- Before maintenance, adjusting, cleaning, threading or replacing the needle, and to

prevent accidents, be sure the power is turned off. Check that the machine will not operate when the pedal is pressed.

Note

In case a clutch type motor is used, it will keep on rotating by inertia after turning off power supply ①. If the machine pedal ② is stepped on inadvertently, it is dangerous because the machine will move unexpectedly. Keep on stepping on the pedal ② until the machine comes to a stop after turning off power supply.

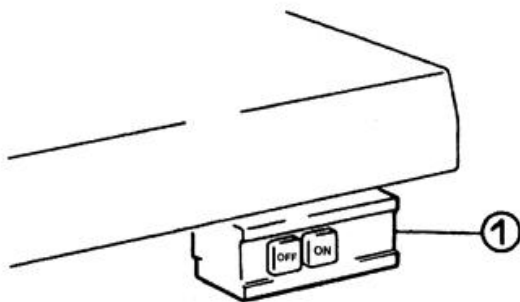

- Turn the power off before leaving the machine table.
- In the event of a power failure, be sure to turn the machine off.
- Check that the machine is securely grounded.

在使用之前
BEFORE
OPERATING

供油 Lubrication

加油量是使油面于H线与L线之间为好。当油量低于L线时，就要及时补充机油。

After filling the oil pan, the oil surface should lie between (H) and (L) lines. Add oil, when the oil surface reaches or goes below(L).

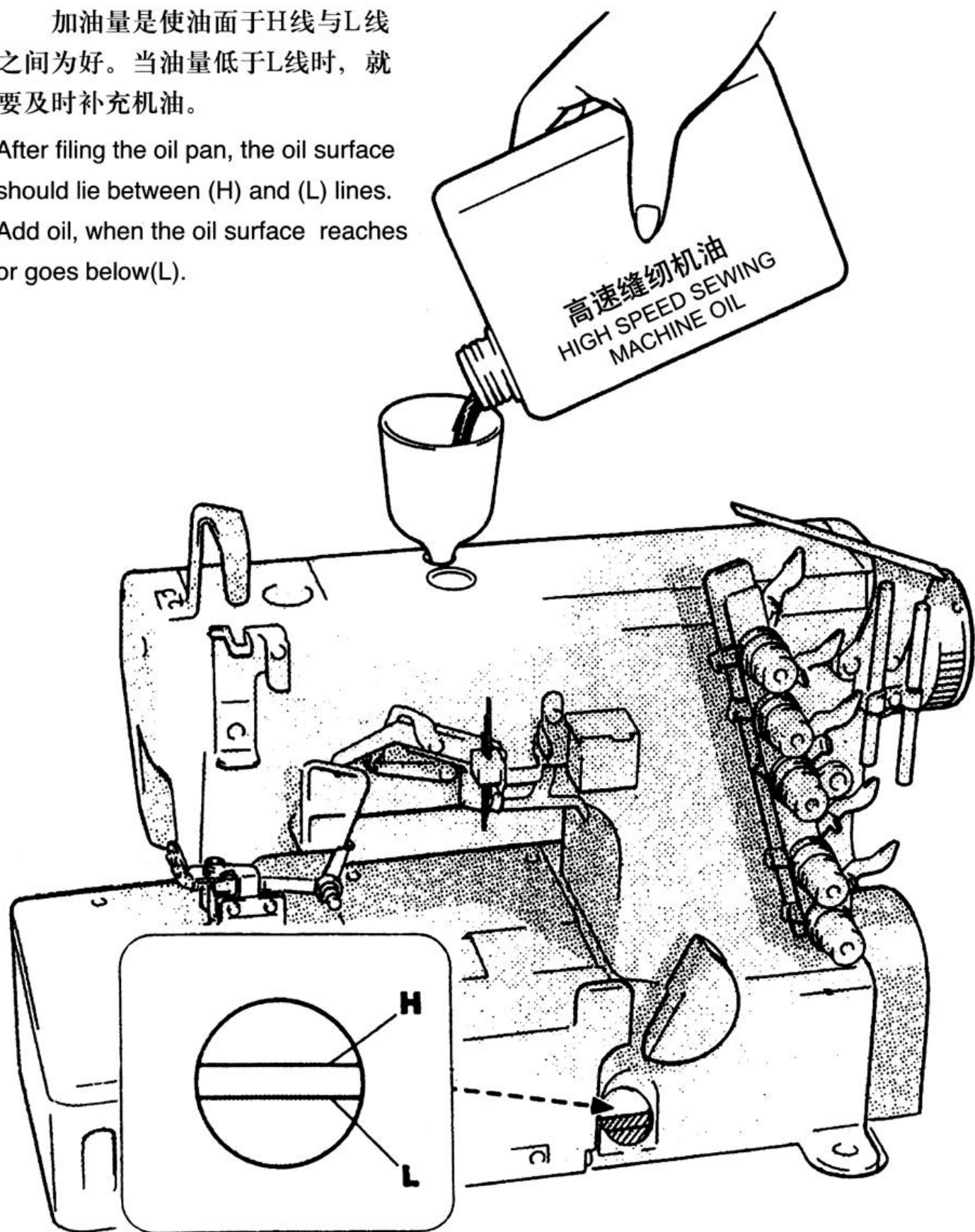

在使用之前
BEFORE
OPERATING

手动给油 Manual lubrication

手动给油是在缝纫机最初开始使用时，或相当一段时间没使用了时，请供给2~3滴油。

Apply 2 or 3 drops of oil by hand when the machine is used for the first time or has been left unused for some time.

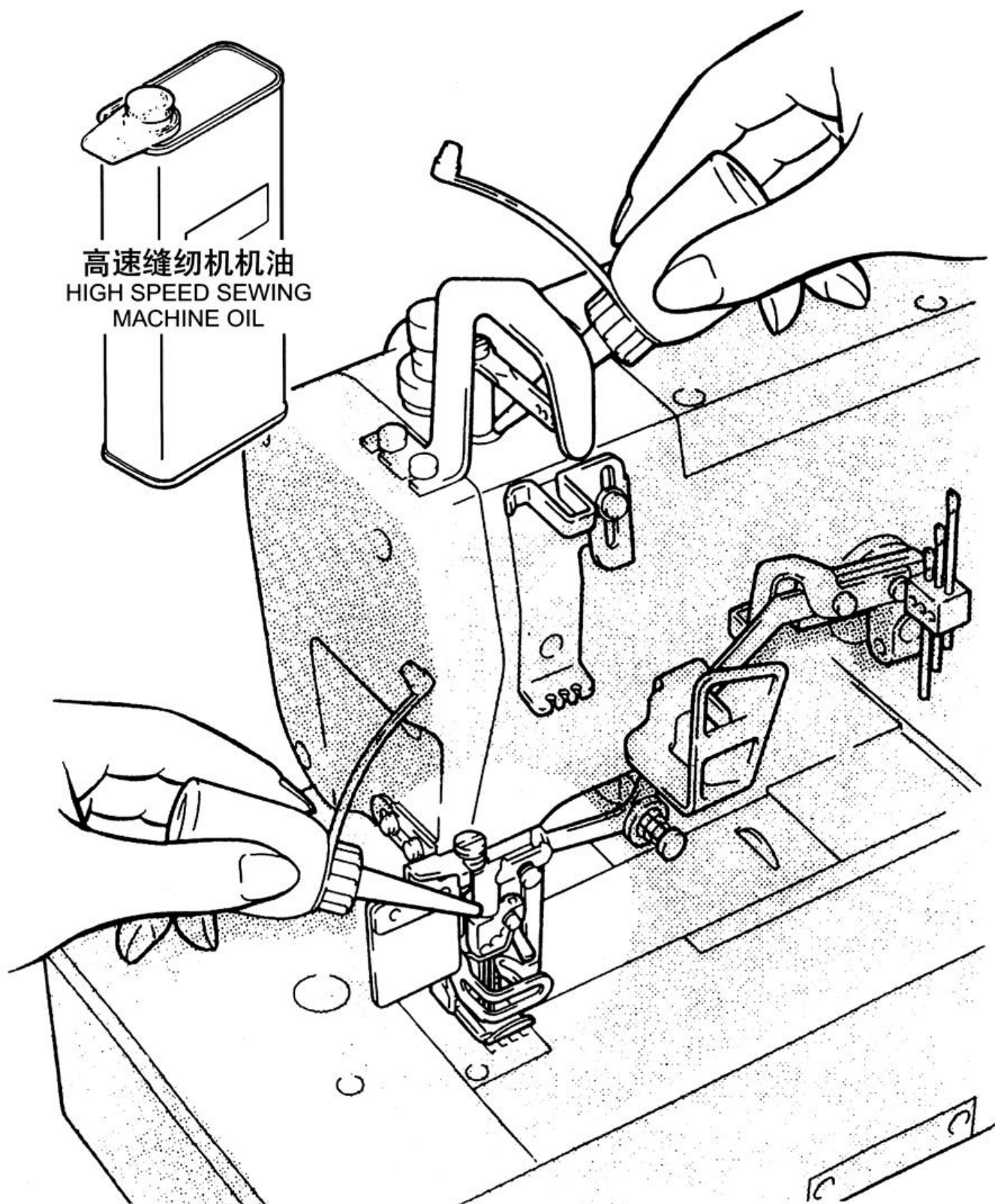

在使用之前
BEFORE
OPERATING

给HR装置供油 Filling the HR device with silicon oil

为了防止布纤维或线被切断，请尽早给HR装置供油。

Fill the device with oil before it is too low in order to prevent needle thread breakage and fabric damage.

注：关于购买硅酯油，请咨询缝纫机
代销店或与公司营业所联系。

Note: Use recommended silicon oil.
(UNION CARBIDE CORPORATION)
UCCL-45(350)

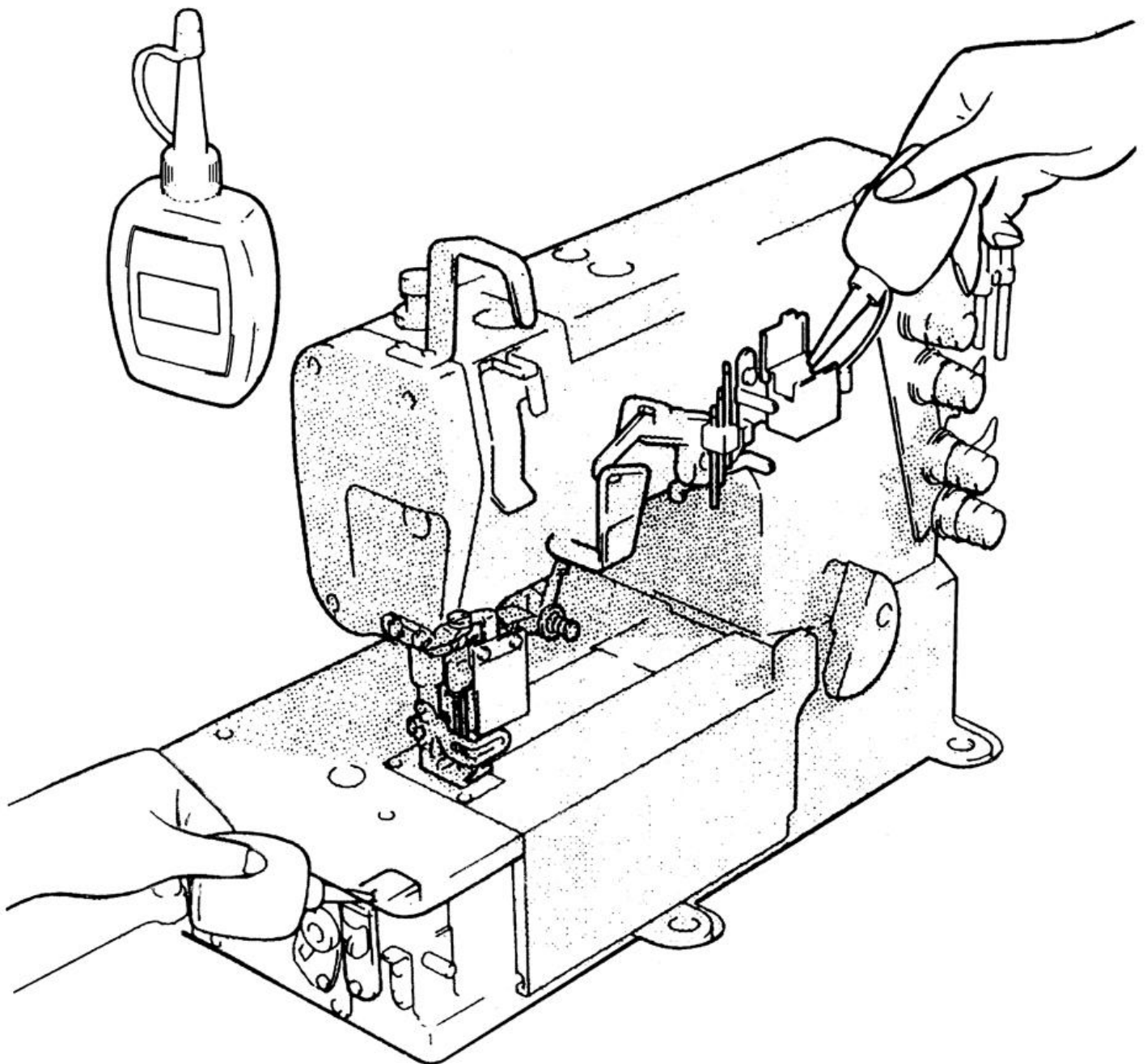

在使用之前
BEFORE
OPERATING

穿线的方法 Threading

① 请掀起护眼板，打开机盖（3处）。
Open the eye guard and three covers.

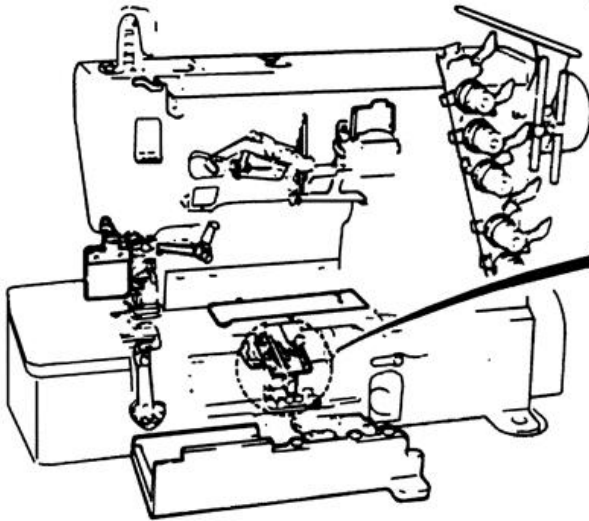

② 提起。
Press down.

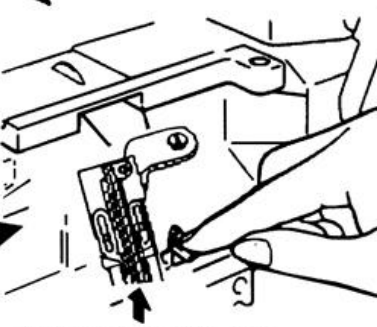

弯针挑线器提到上面。
The looper thread take-up comes out.

④ 穿好线后将弯针挑线器压回原位。
Replace the looper thread take-up after threading.

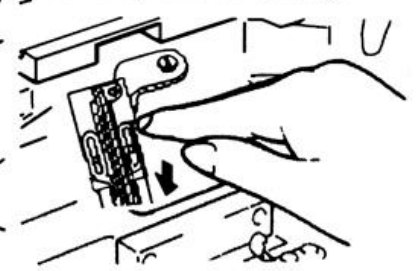

把机上原有的线与缝纫用线
绑结在一起。
Knot the preset thread and the
thread being used together to
thread the machine.

③

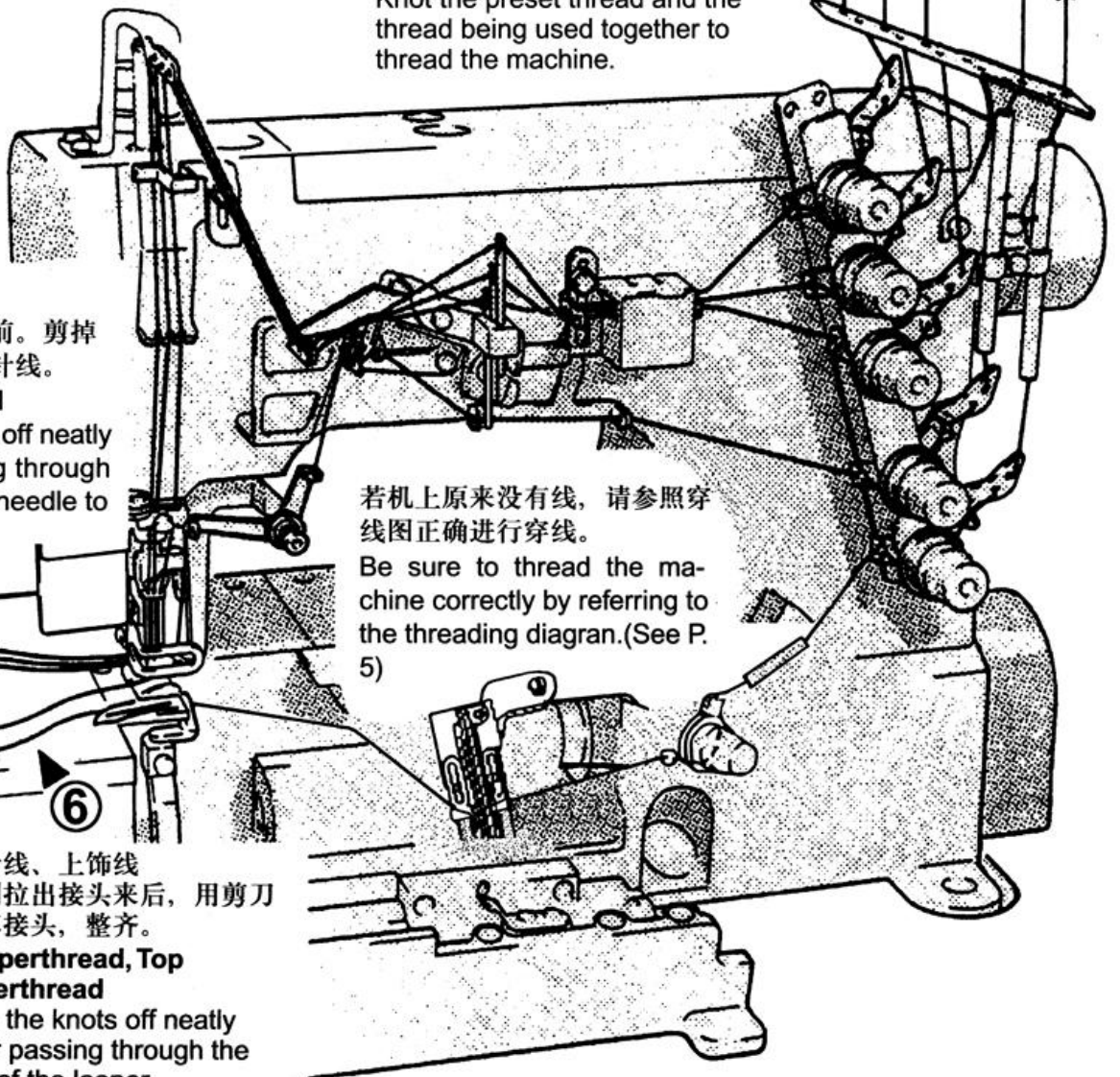

针线
将线拉到针跟前。剪掉
结头再次穿好针线。

Needle thread
Trim the knots off neatly
before passing through
the eye of the needle to
tethread.

若机上原来没有线，请参照穿
线图正确进行穿线。
Be sure to thread the ma-
chine correctly by referring
to the threading diagram. (See P.
5)

⑤

穿针线、上饰线
直到拉出接头来后，用剪刀
剪掉接头，整齐。
**Looper thread, Top
cover thread**
Trim the knots off neatly
after passing through the
eye of the looper

在使用之前
BEFORE
OPERATING

穿线图(2针、3针、4针)

Threading diagram (2.3.-needle)

①



若使用伸缩大的线时，为点线(A)方向。
Broken lines (A) For more stretchable thread.

②

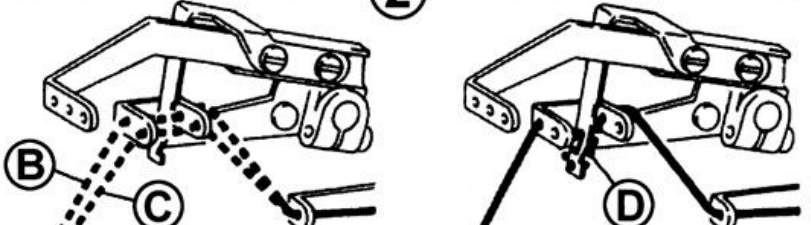

饰线太松弛时用(B)，用(B)仍松弛时用(C)。
If the top cover thread is too loose, use broken line (B). If the top cover thread is still too loose after thread with broken line (B), use broken line (C).

饰线太紧时用(D)
If the top cover thread is too tight, use broken line (D).

Solid lines
for ordinary thread

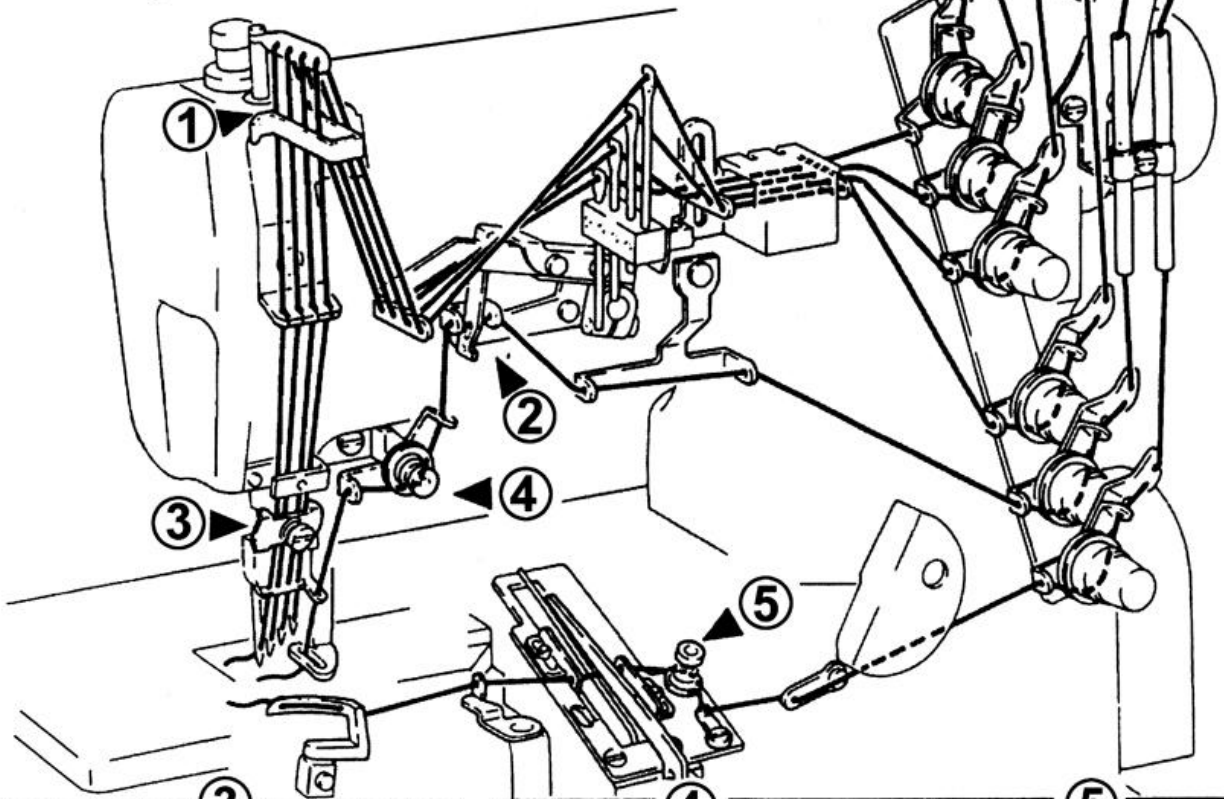

③

穿伸缩大的线时
For more stretchable thread



穿伸缩小的线时
For less stretchable thread



④

穿伸缩大的线时用点线(E)方向。
Broken lines (E)
For more stretchable thread





在使用之前
BEFORE
OPERATING

压脚压力的调节 Presser foot pressure

压脚压力的调节是松开螺帽①和旋转螺丝②来进行的。在能取得平稳针脚的范围内，尽量调得松一些为好。

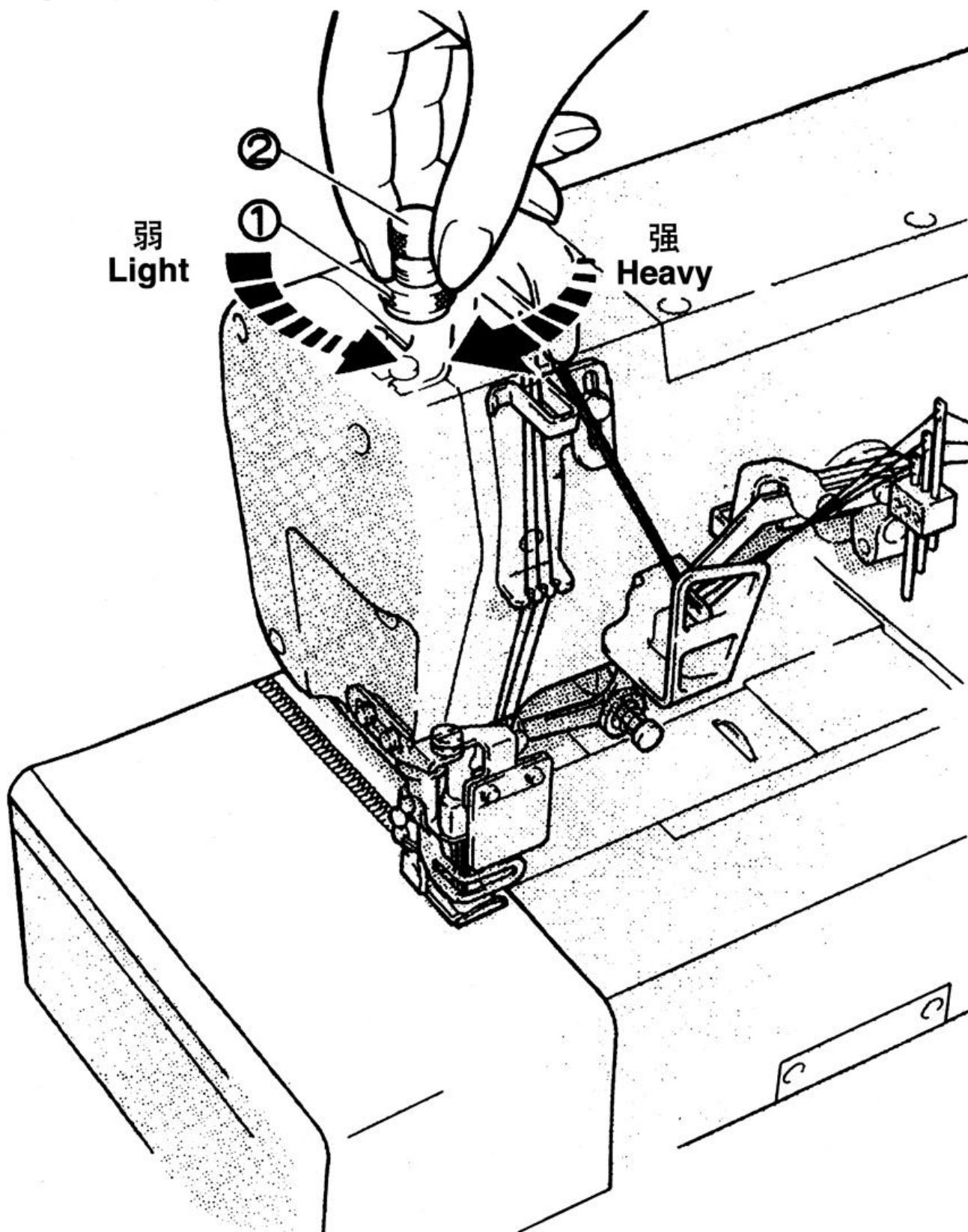
Loosen adjusting (1) nut and turn adjusting screw (2) to adjust the presser foot pressure. It should be as light as possible, yet be sufficient to obtain the proper stitch formation.



差动比是通过松开螺帽①后，把调节杆②上下移动来进行调节的，调节后请拧紧螺帽①。

Loosen nut (1) and move the lever up (2) and down to obtain the correct differential feed ratio. then tighten nut (1).

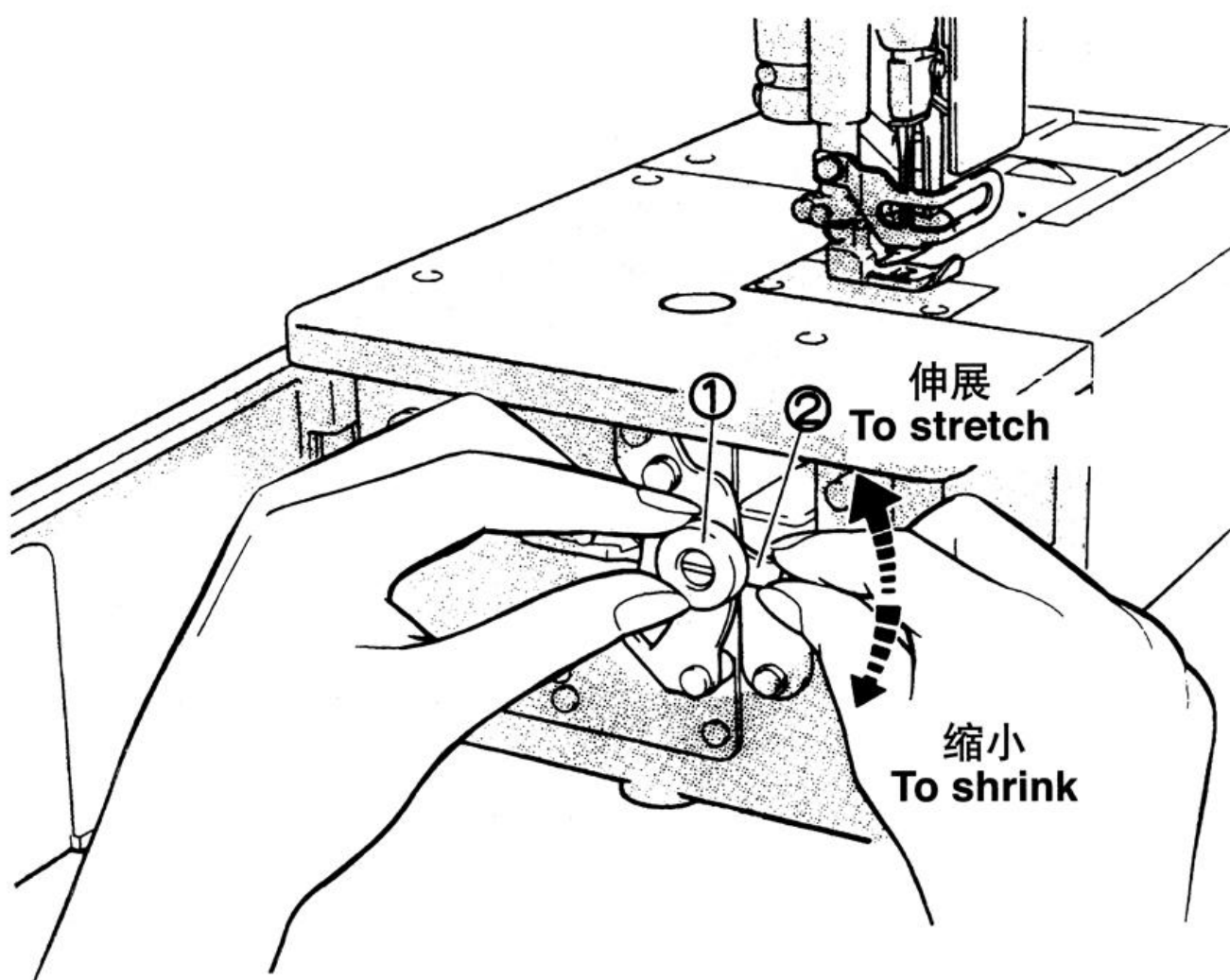

- ① 摁住针距调节按钮，旋转手轮，针距调节按钮会陷进更深处。
- ② 这时边摁住针距调节按钮，边转动手轮，使校准标记对准所希望的数值。

注：针脚长度的调节务必请在调节差动比之后进行。

While pressing the push button, turn the handwheel to seek the position at which the push button goes further into the depth. Then, keeping the push button pressed, turn the handwheel and set the desired scale to the aligning mark.

Note: Stitch length adjustment must only be made after the differential feed ratio has been changed.

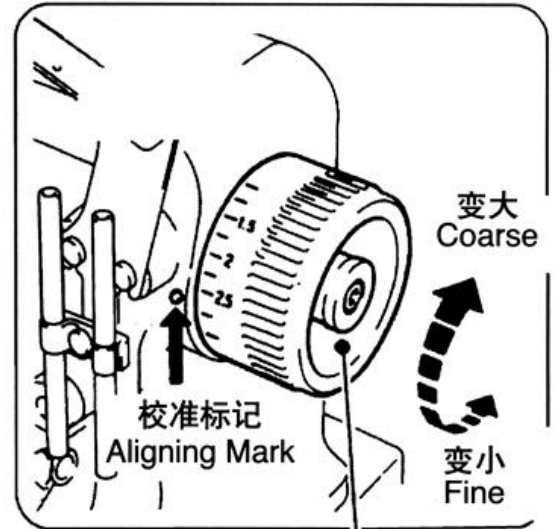

手轮
Handwheel

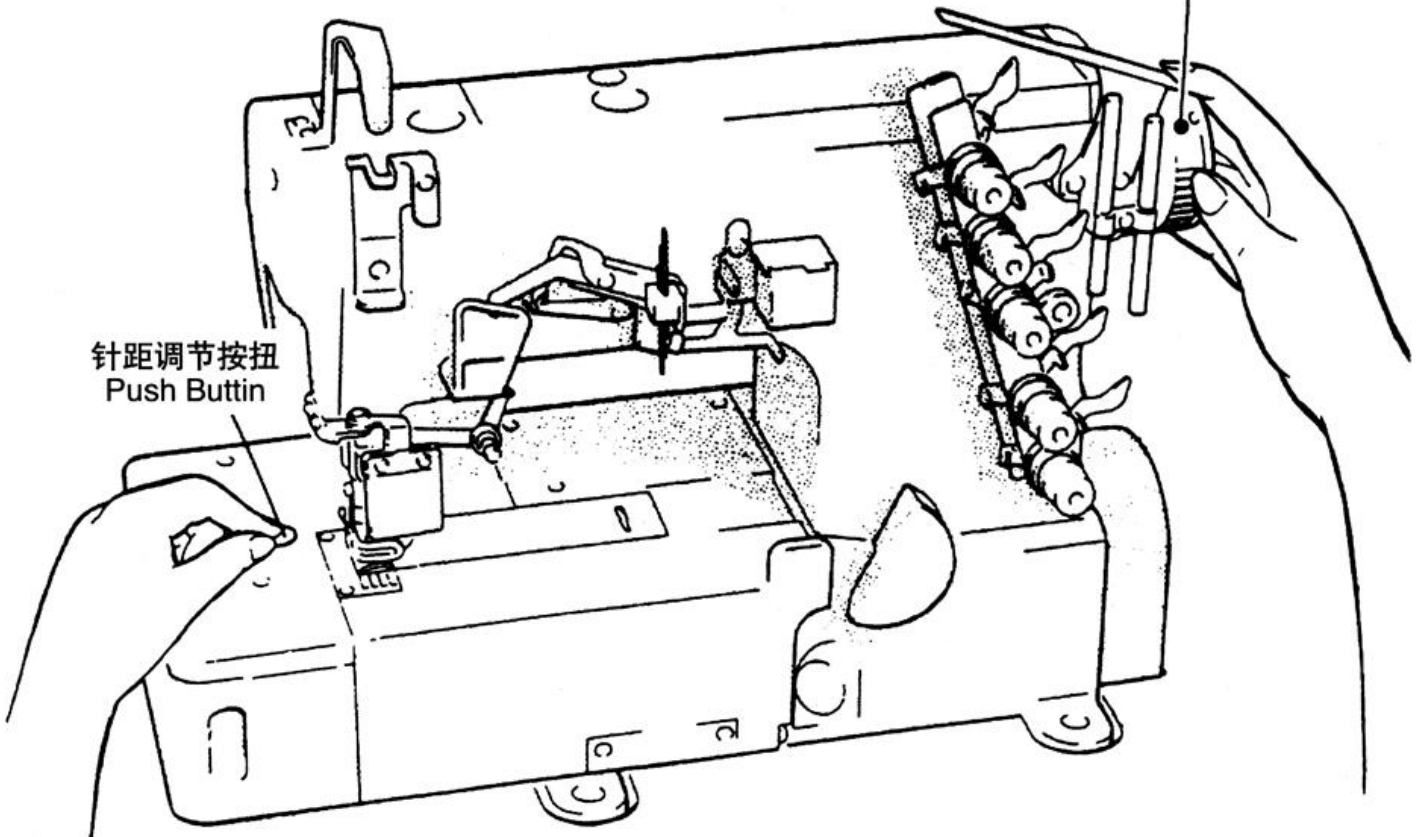

针距调节按钮
Push Button

试 缝
TEST SEWING

线状态的调节

Thread tension

线张力状态的调节，请用针线状态螺帽①、上弯针状态螺帽②、弯针线状态调节螺帽③来进行调节。

Mack tension adjustments with the needle thread knob (1), top cover thread knob (2), and looper thread knob (3).

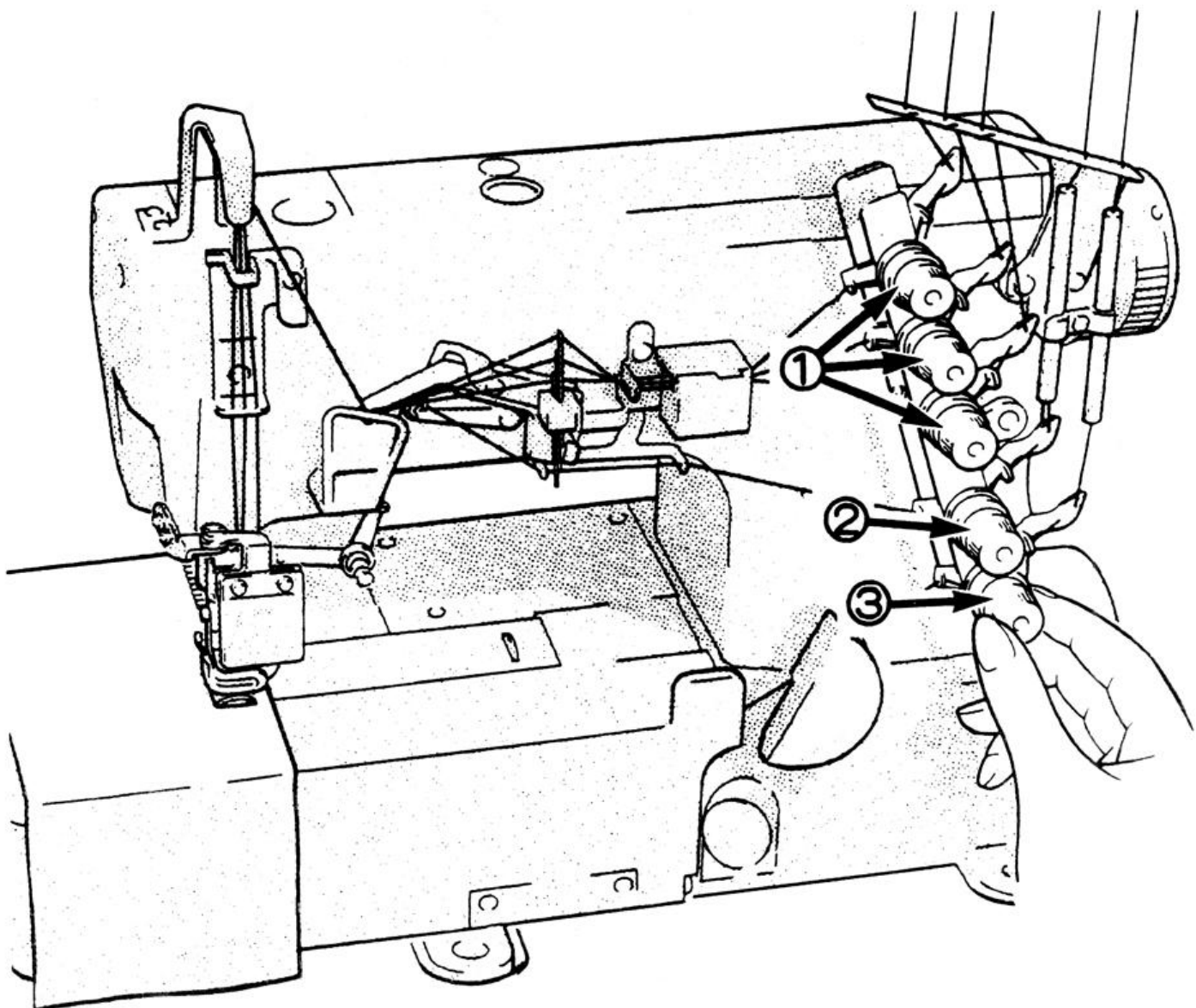

使用中的保养
MAINTENANCE
DURING USE

缝纫机的清扫 Cleaning the machine

缝纫机的清扫，以针板槽及送布牙周围为主。

Mainly the slots of the needle plate and the feed rows should be cleaned.

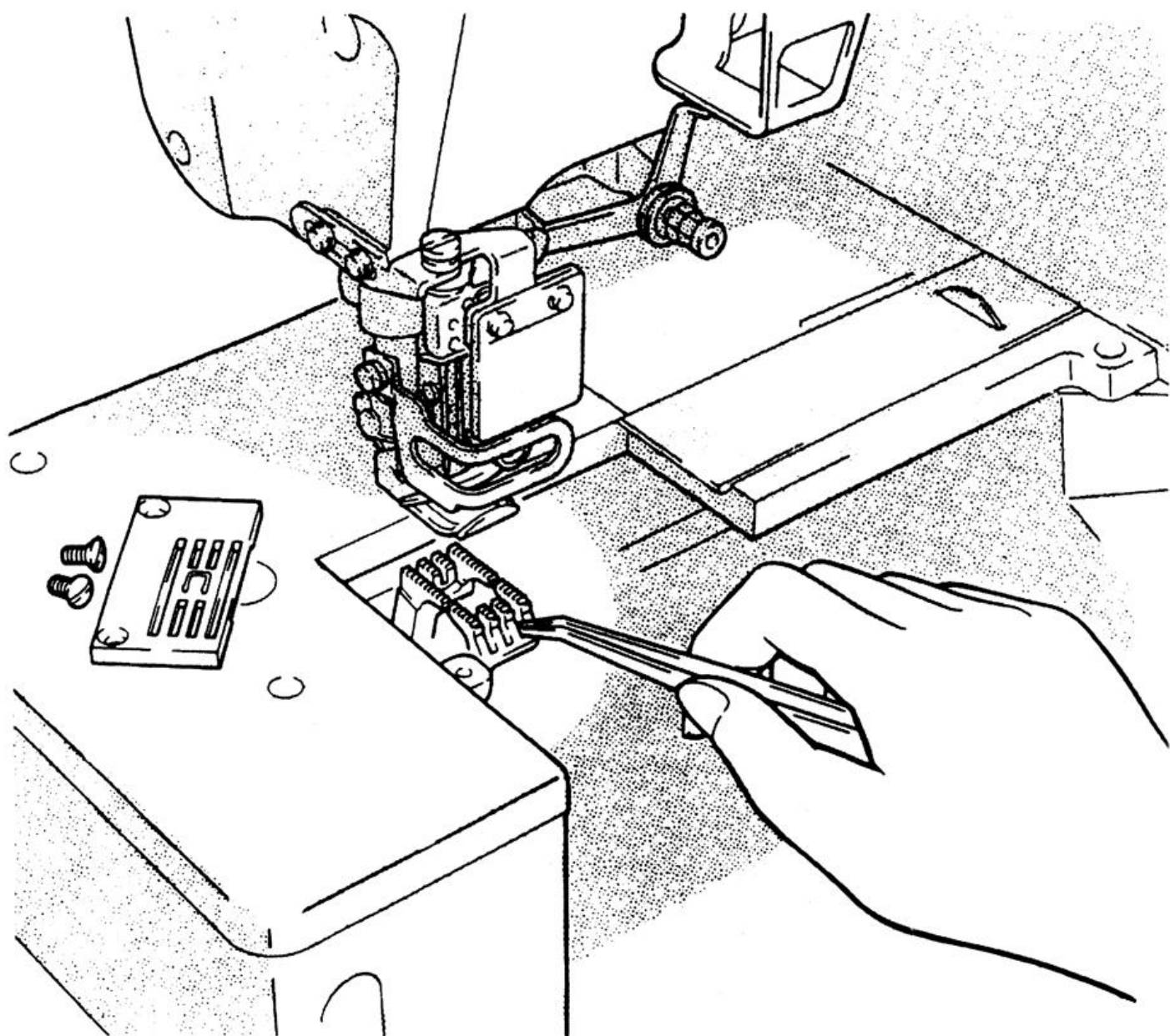

换 针

Replacing the needle

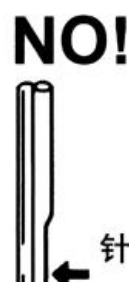
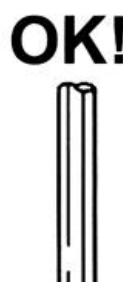
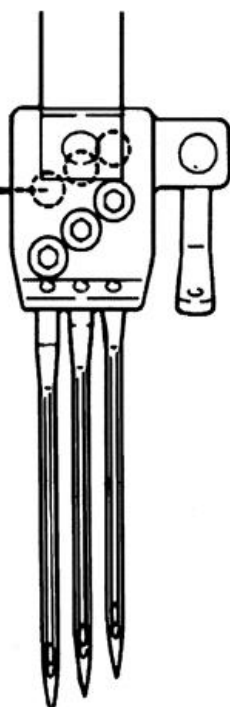

针凹部分
Scarf

准确辨认针的前后，请将针凹向着后方，即背向操作者进行安装。

针要牢固的插到孔的最里头。

*Check the needle carefully to see that the scarf is turned to the rear of the machine.

*Insert the needle to the proper depth, and fasten securely.

标准用针
Standard needle

		针的尺寸 NEEDLE SIZE	
		2 针 2-needle	3 针 3-needle
风琴牌 Organ	UY128GAS	# 9	# 10
蓝狮牌 Schmetz	UY128GAS		
UY128GAS			
UY128GAS			

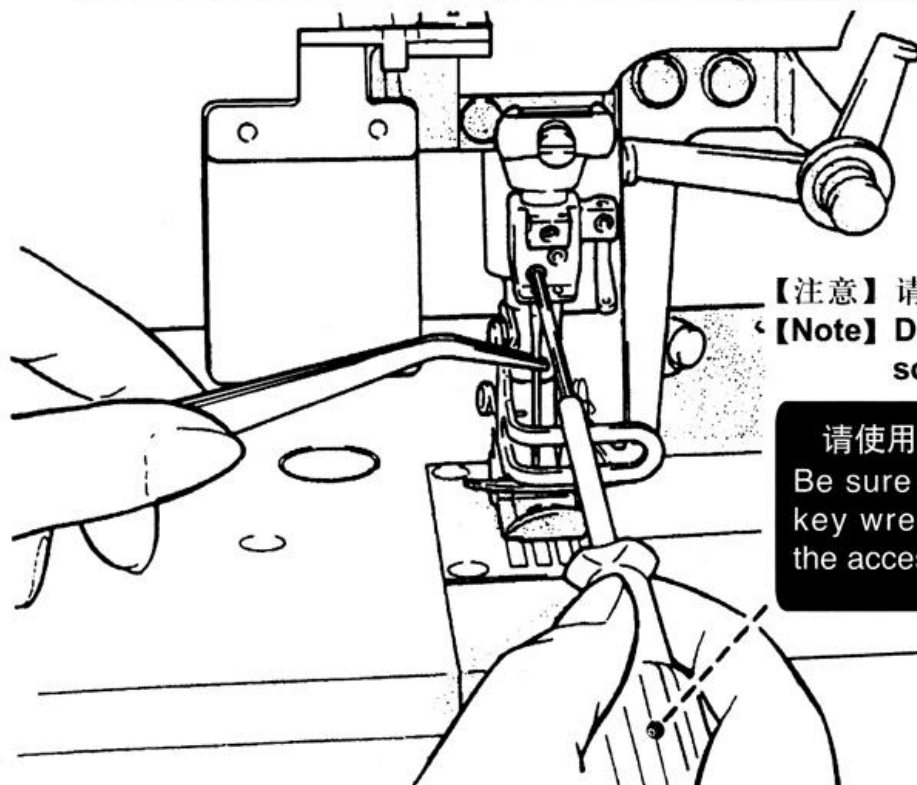

【注意】 请不要把螺丝卸下来。
【Note】 Do not remove the screw.

请使用附属品的螺丝板
Be sure to use the allen key wrench packaged in the accessory box.

使用中的保养
MAINTENANCE
DURING USE

检查机油的循环 Checking the oil circulation

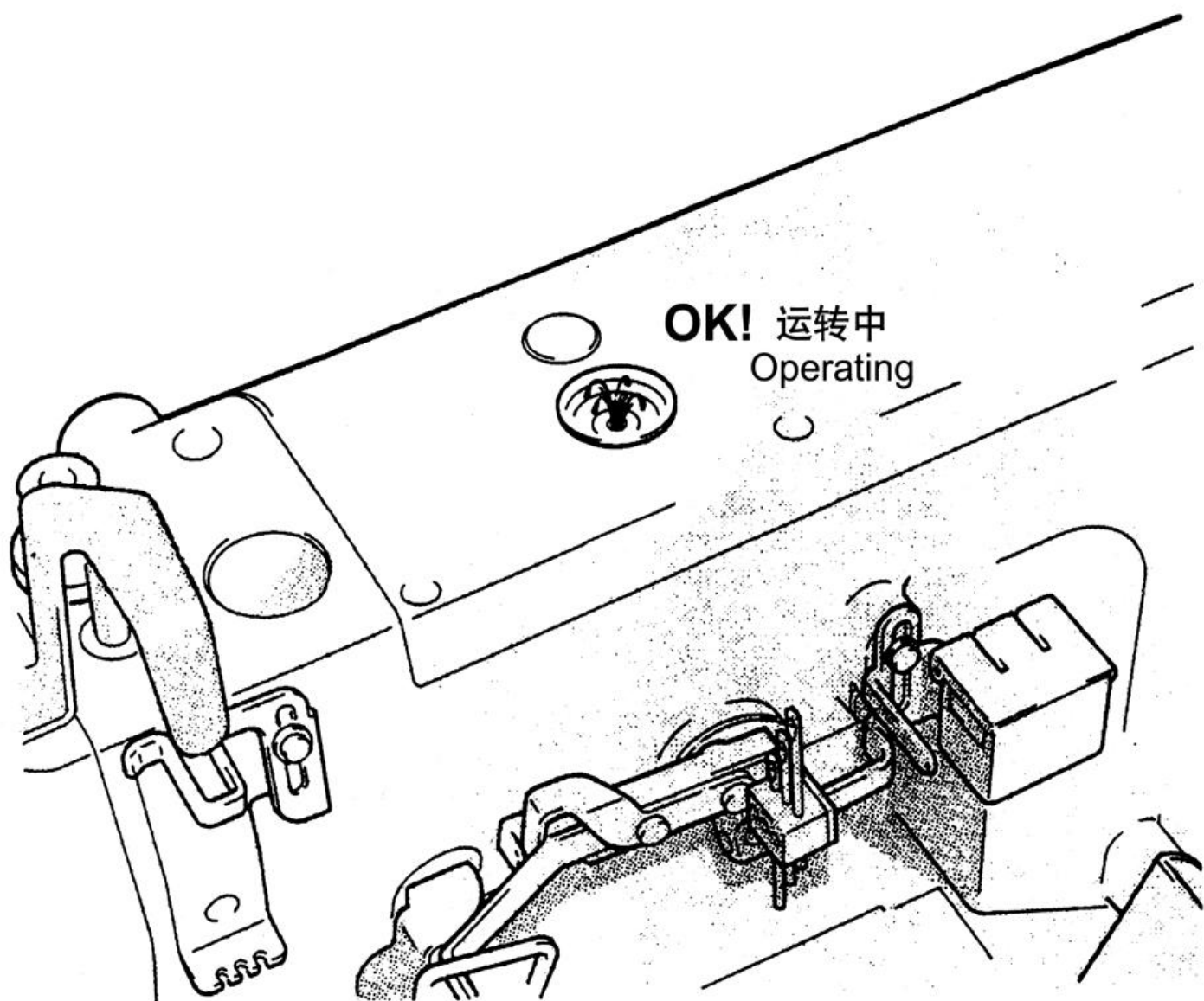

机油过滤器，请于每6个月拆下来检点或更换一次。
Check and replace the oil filter every six months.

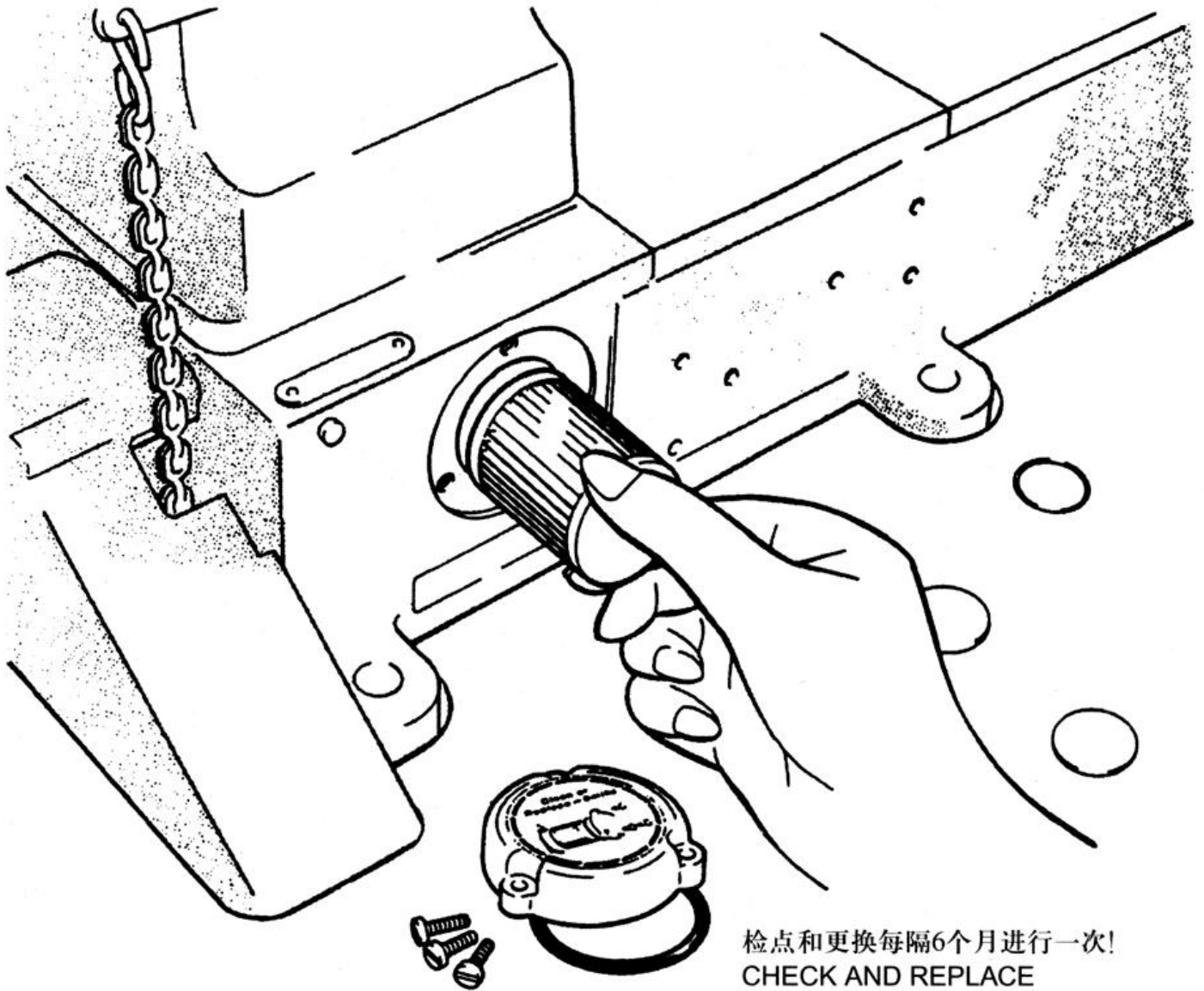

检点和更换每隔6个月进行一次!
CHECK AND REPLACE
EVERY 6 MONTHS!A

注：缝纫机附带有UT装置时，请拆下螺线管托架。

NOTE: On machines fit with a UT Device, remove the solenoid bracket.

换机油

Replacing the oil

机油的更换，请在使用开始1个月后更换一次。
然后，每6个月更换一次。

Replace the oil one month after the first use
and every six months thereafter.

供油请参见第1页 (See P.1)

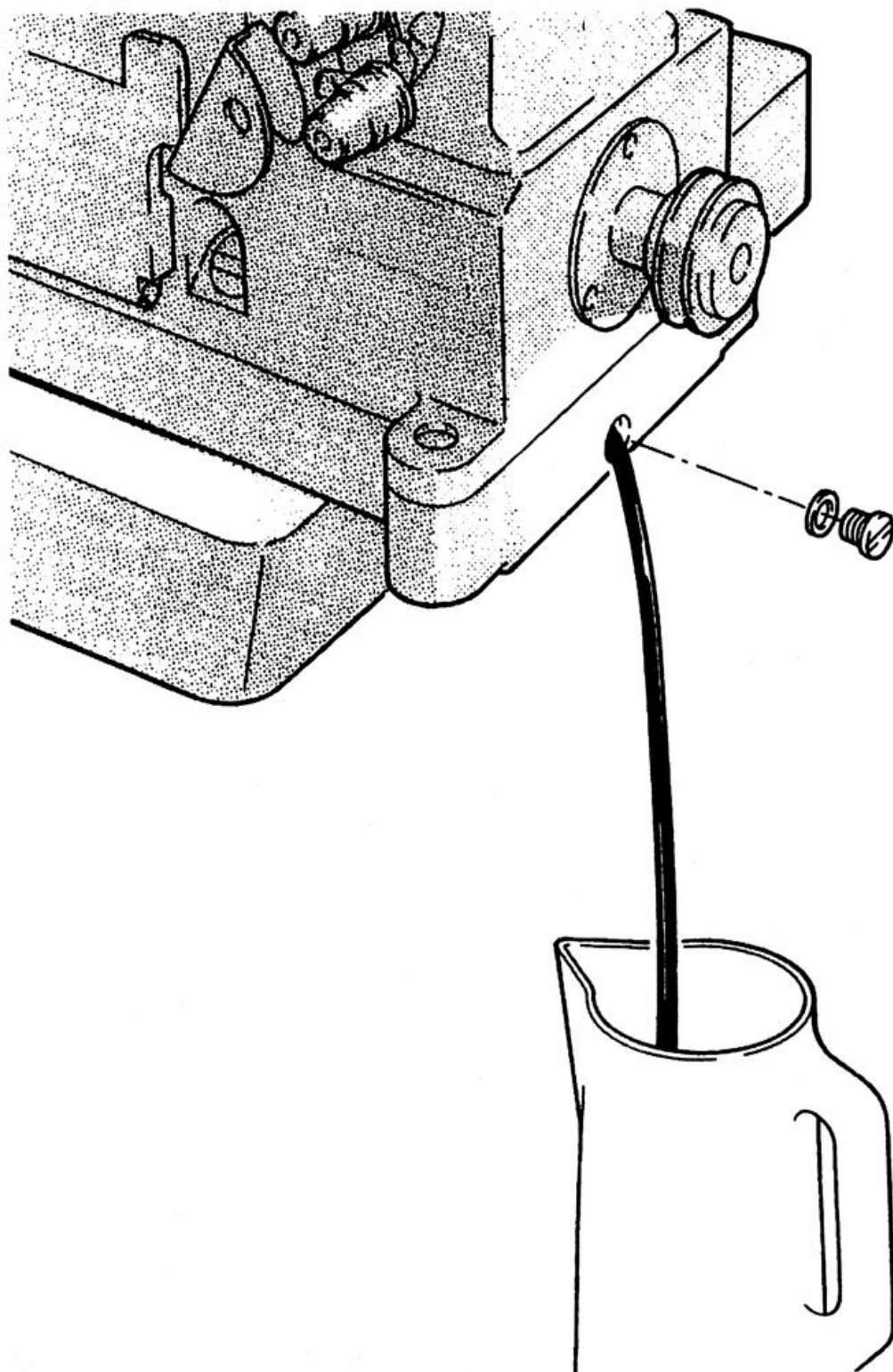

500 调整标准参数表 500 Adjustment Dimensions (mm)

500-01CB	224	10.2	4.8~5.1	8.3~8.7	4.5~5.0	17.0	0.8~1.2					
02BB	232	9.8	4.4~4.7	8.3~8.7	4.5~5.0	17.0	0.8~1.2					
03EB	248	8.9	3.6~3.9	8.3~8.7	4.5~5.0	17.0	0.8~1.2					
04DB	256	8.5	3.2~3.5	8.3~8.7	4.5~5.0	17.0	0.8~1.2					
05MD	264	8.1	2.8~3.1	8.3~8.7	4.5~5.0	17.0	0.8~1.2					
06HD	348	9.4	3.6~3.9	8.3~8.7	4.5~5.0	17.0	0.8~1.2					
07FD	356	8.5	8.3~8.7	8.3~8.7	4.5~5.0	17.0	0.8~1.2					
08AB	364	8.1	2.8~3.1	8.3~8.7	4.5~5.0	17.0	0.8~1.2					

针号对照表

Japanese size (Organ)	#	9	10	11	14	16	18	21
♯Metric size (Schmetz)	Nm	65	70	75	90	100	110	130

标准用针

500-01CB		Organ
02BB	X□□□	UY128GAS
02EB	224	9S
04DB	232	9S
	248	9S
05MD	256	9S
06HD	264	9S
	348	10S
07FD	356	10S
08AB	364	10S

1

车壳部份

Frane assembly

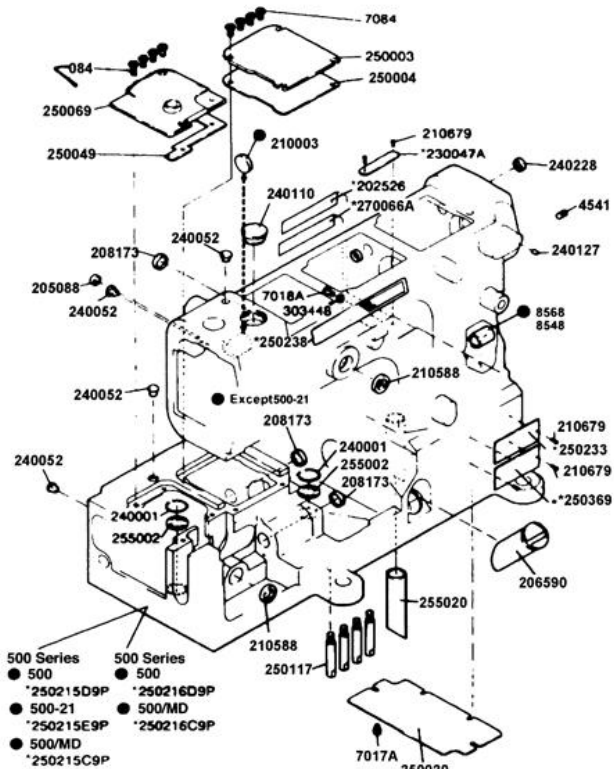

2

罩壳部份

Cover assemblies

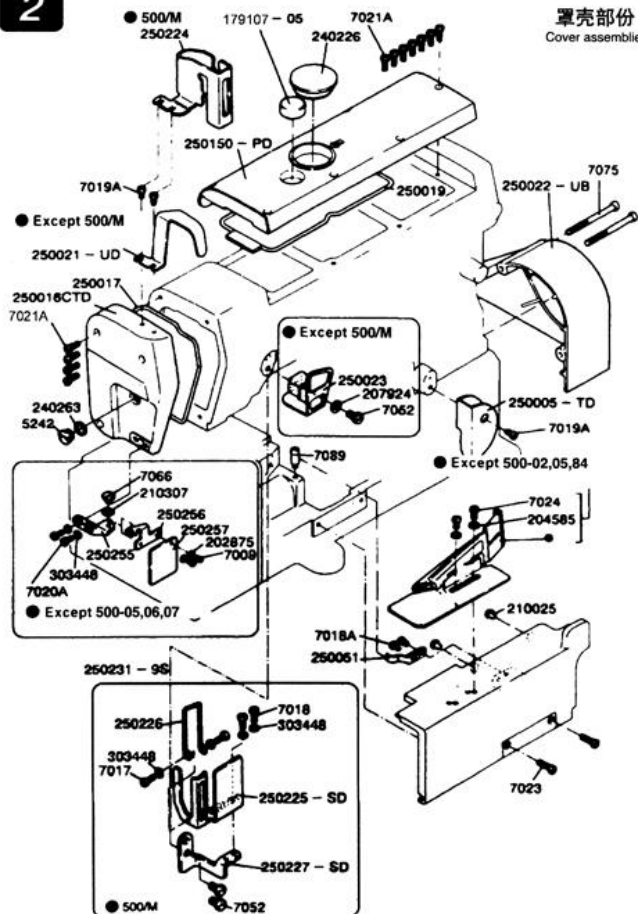

3

缝台部份

Cloth plate assemblies

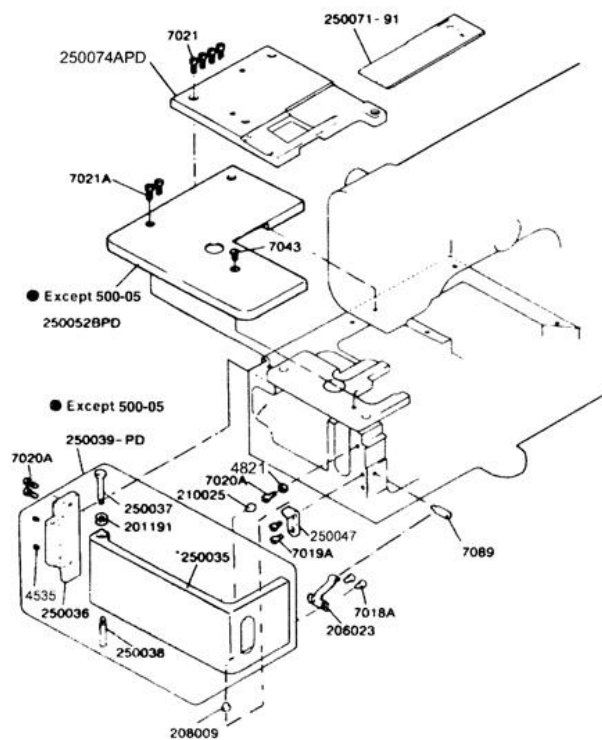

4

下轴部份

Hook shaft assemblies

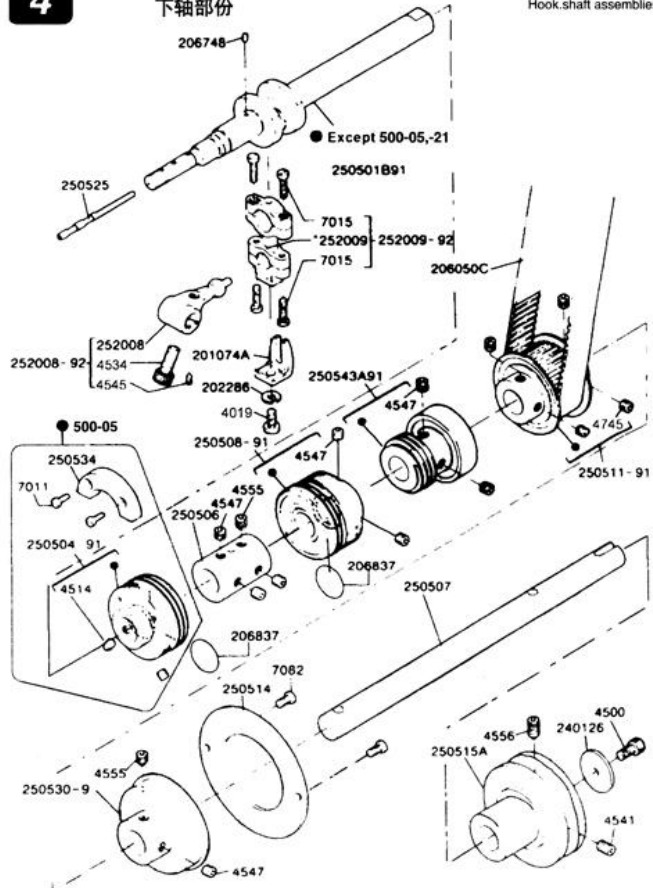

5

上轴部份

Main shaft assemblies

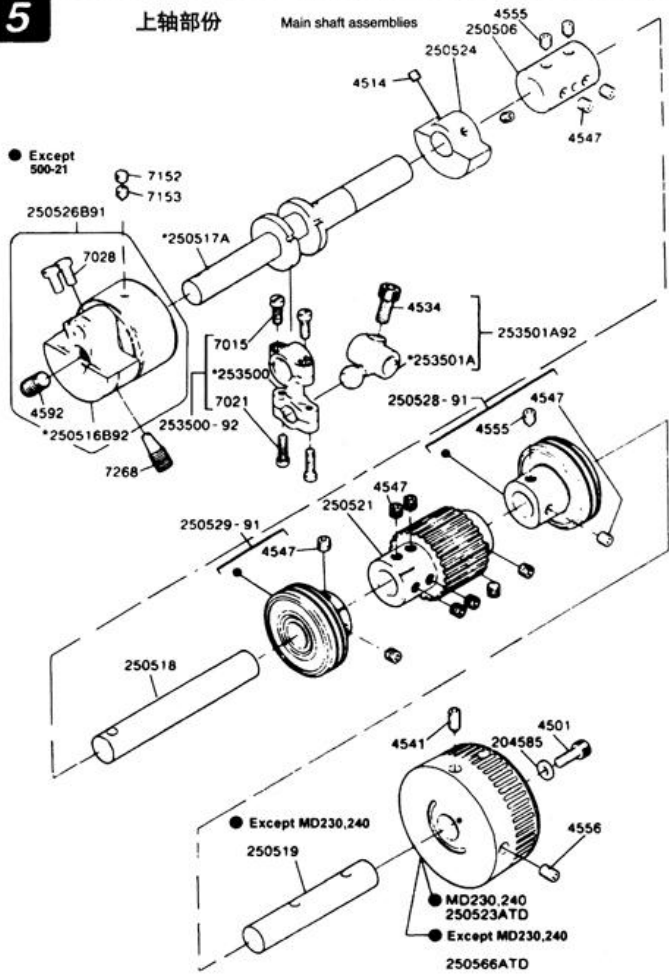

6

针杆部份

Needle bar assemblies

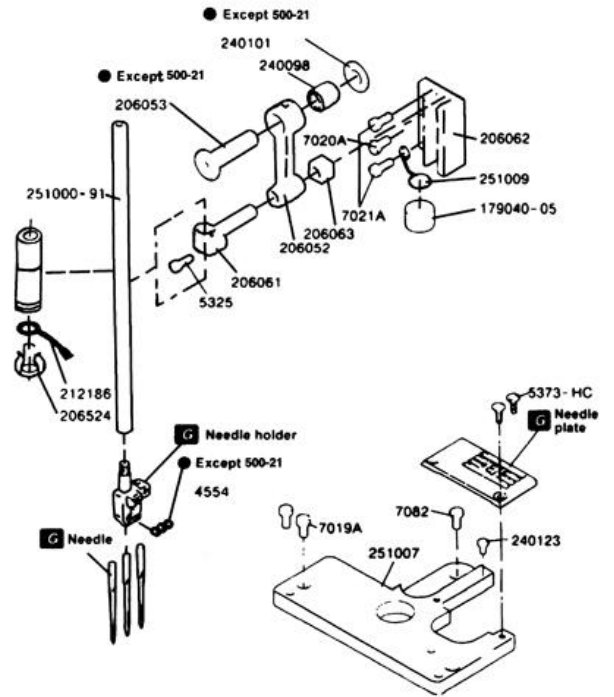

7

护针部份

Needle guard assemblies

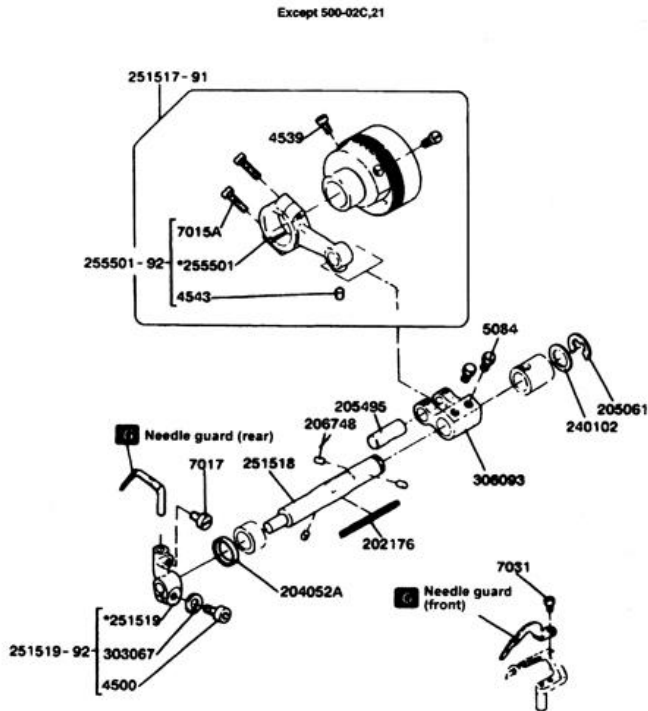

8

弯针部份

Looper assemblies

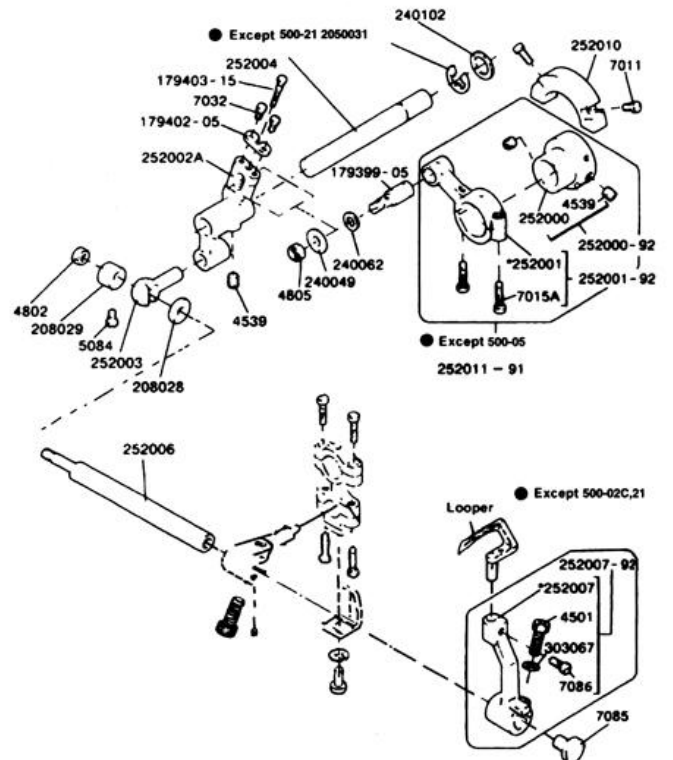

9

牙架部份

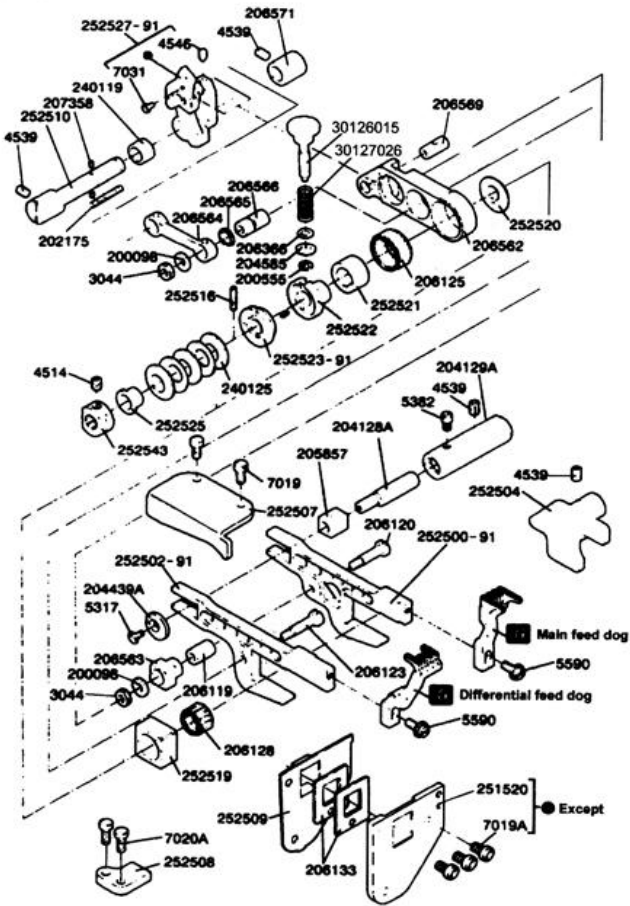

10

差动部份

Differential assemblies

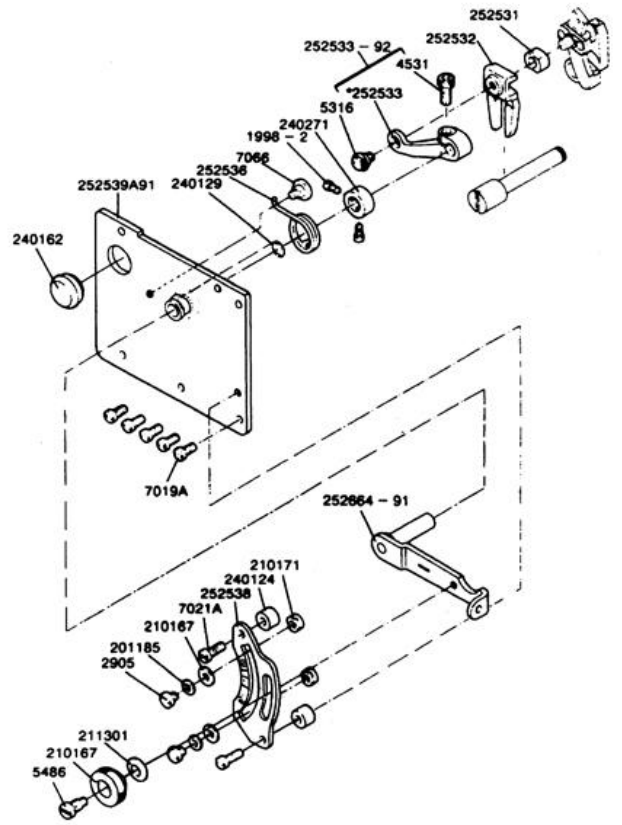

11

压脚部份

Presser form assemblies

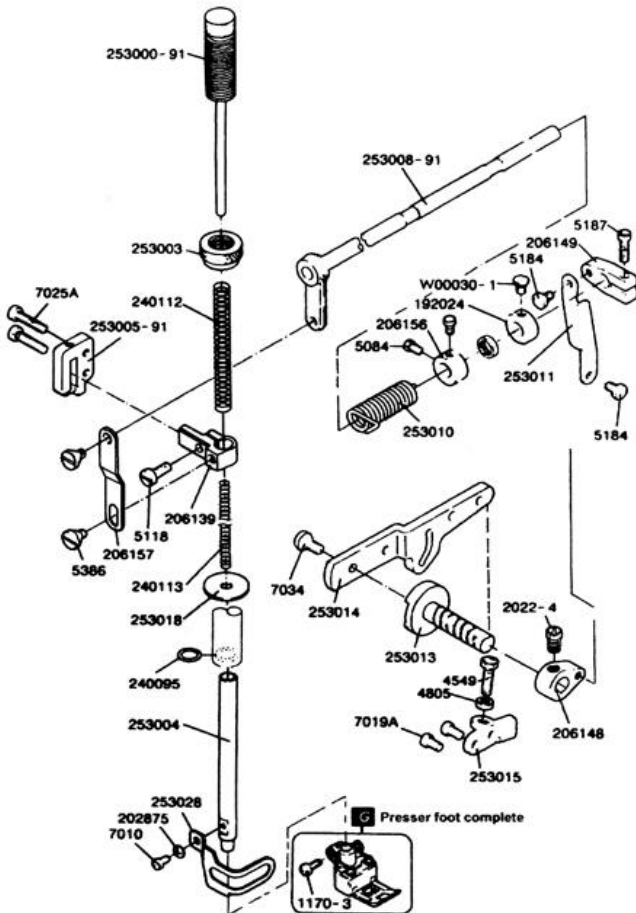

12

喂针部份

Needle feeding assemblies

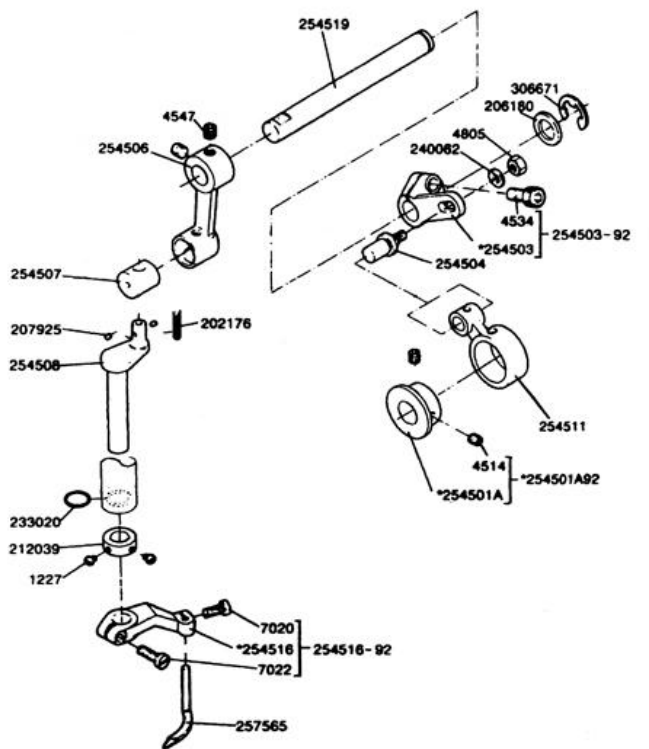

*(not for sale.)

13 松线部份

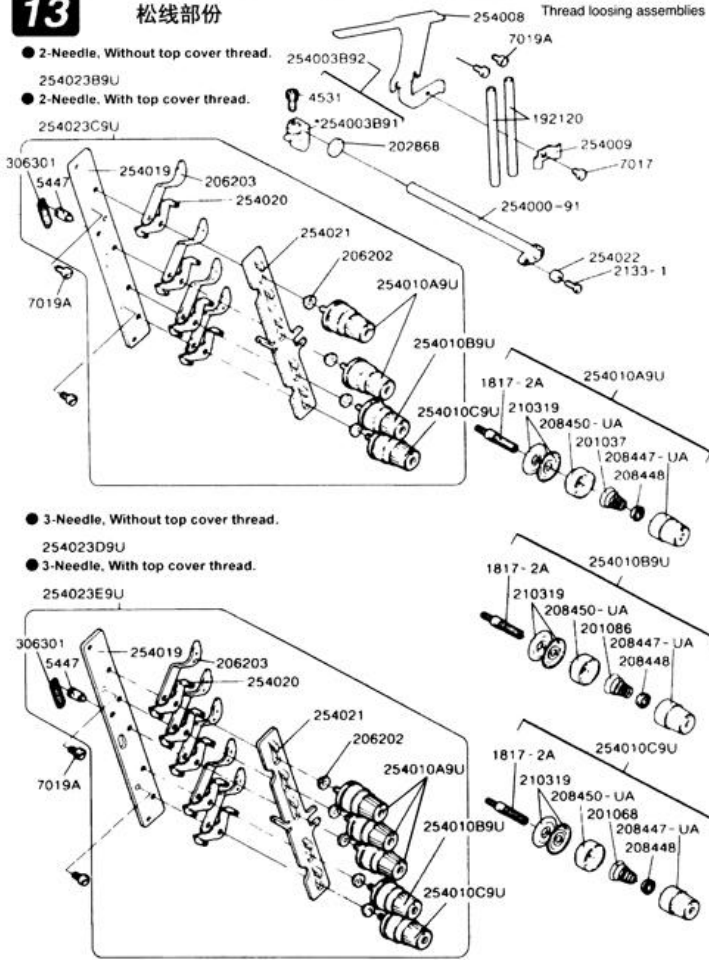

14 过线部份

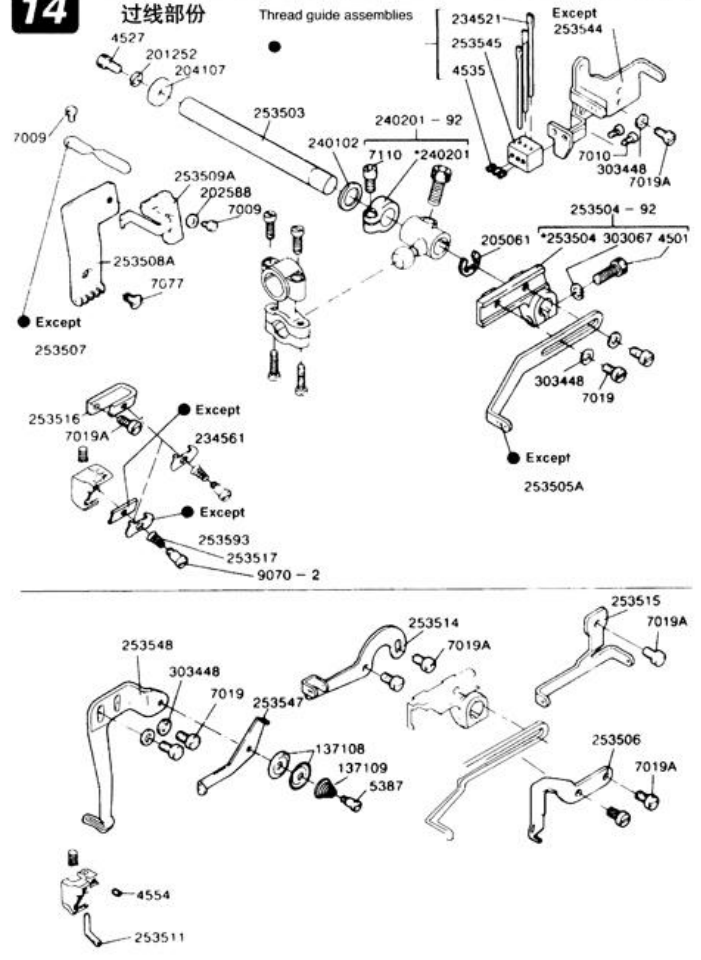

15 过线凸轮部份

Cam assemblies

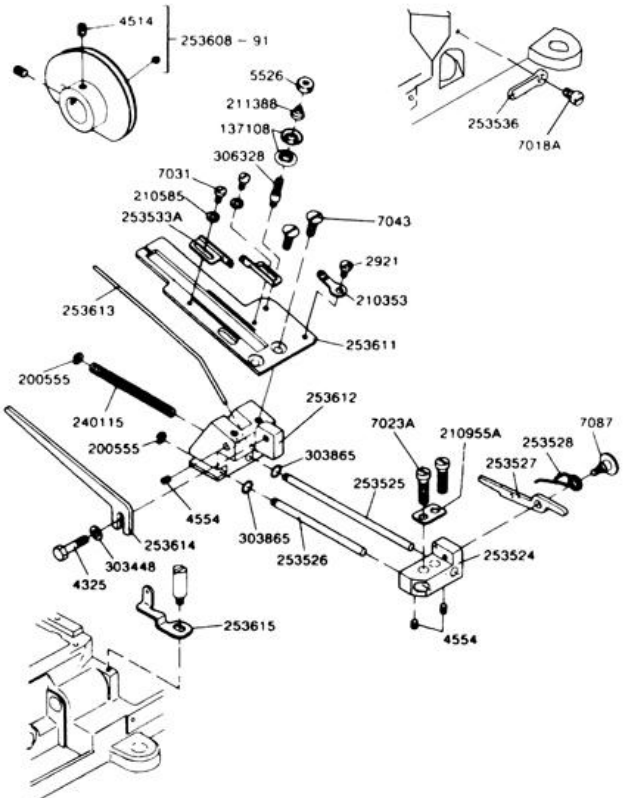

16 润滑部份

Lubrication assemblies

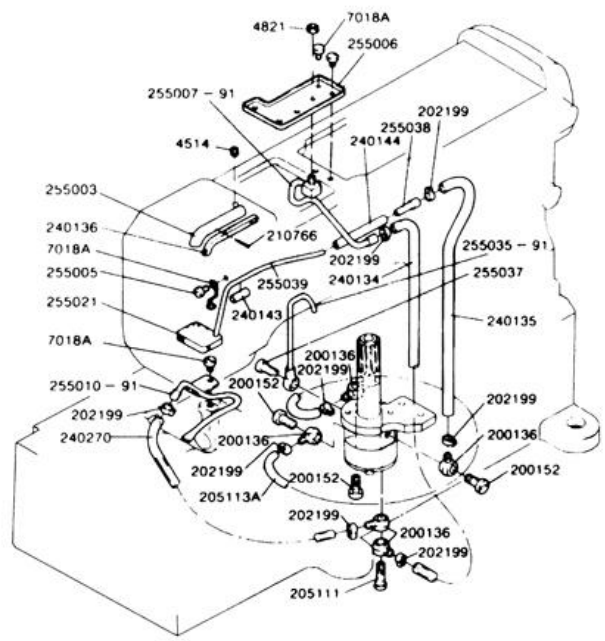

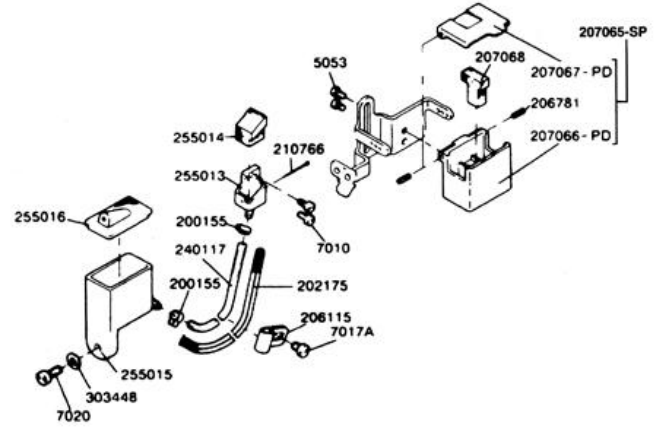
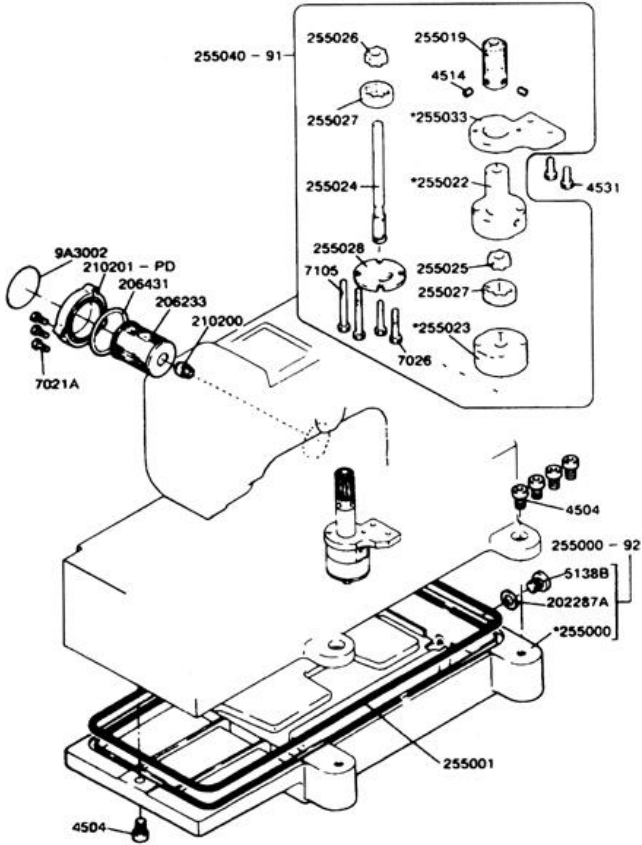

- (6-Spools) 486-9S
- (2-Needle) (3-Needle) (4-Spools) 486B9S
- (5-Spools) (2-Needle) (2-Needle) (3-Spools) 486A9S 486C9S

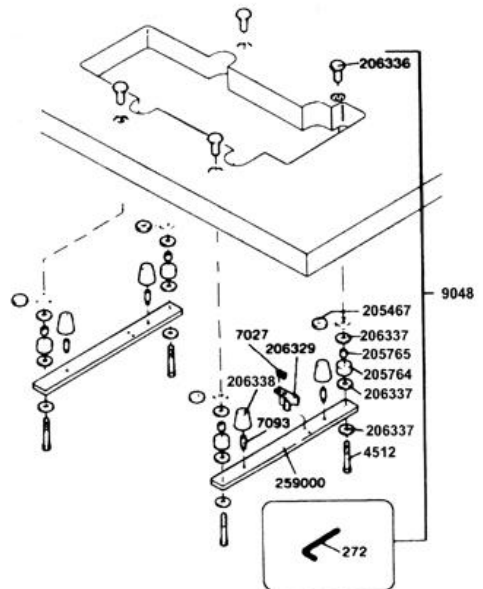
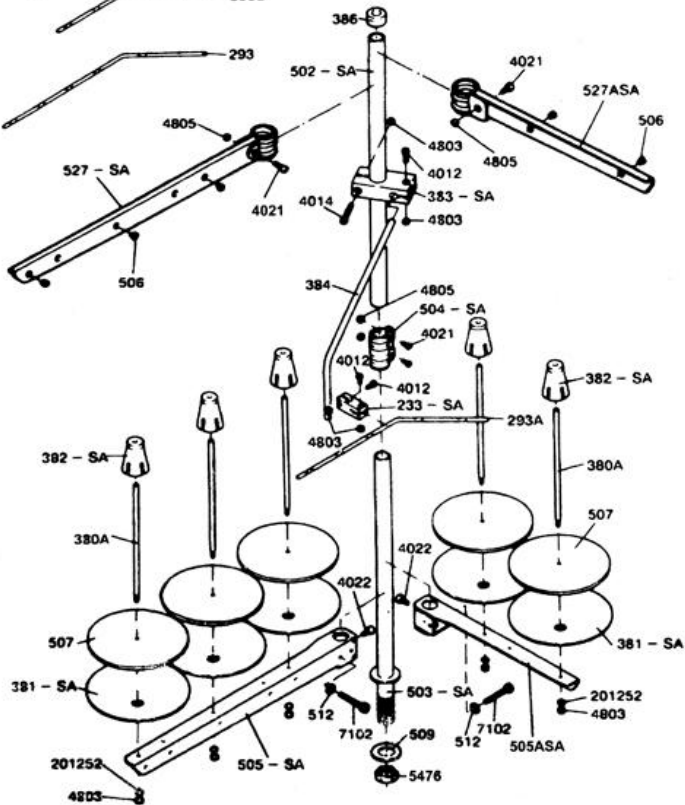

21

● 01(Except-01D,01G),03,21
250030-PD
250032 - PD

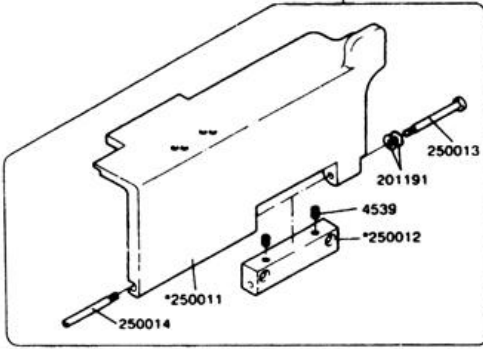

● 06B,07B,08
01D
250032BPD

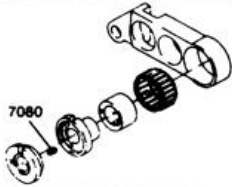
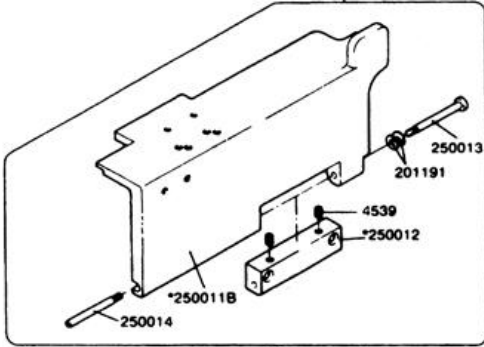

22

01D

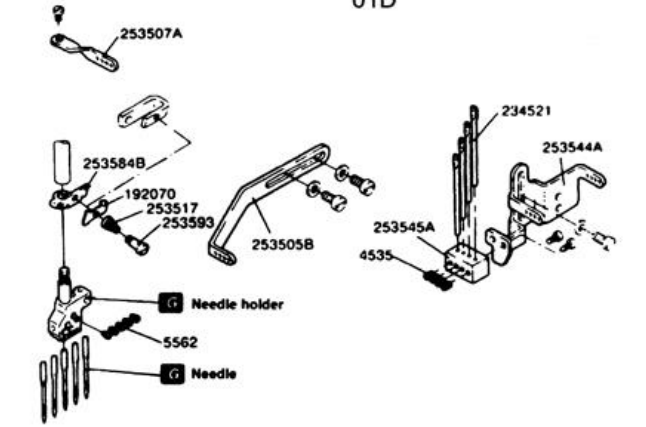

254024 - 9U

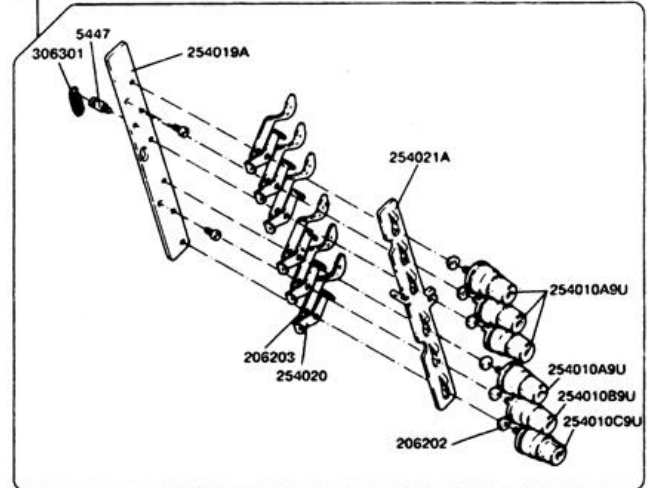

23

● 02B

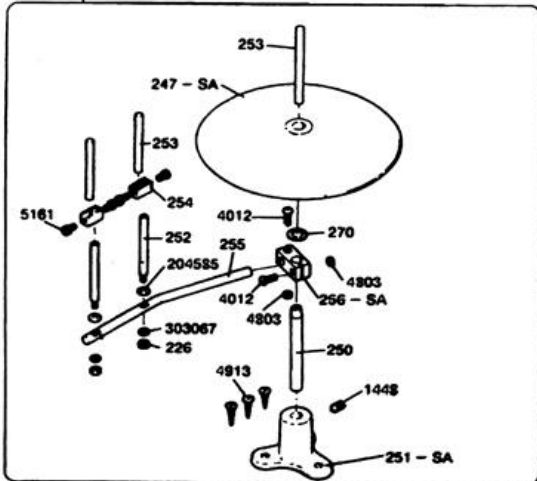
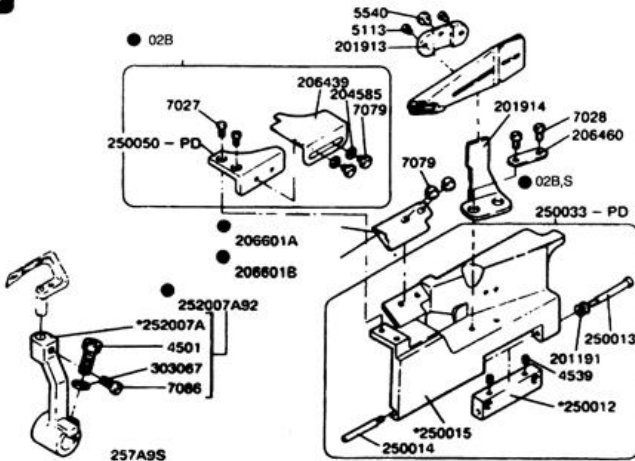

24

03

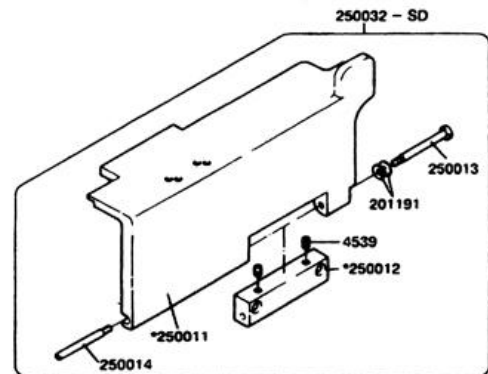

25

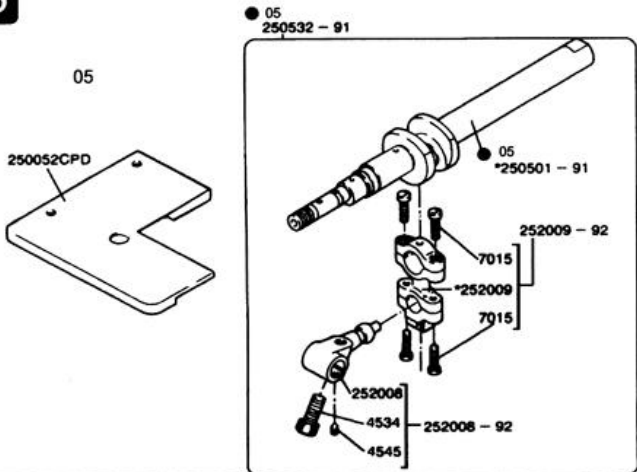

26

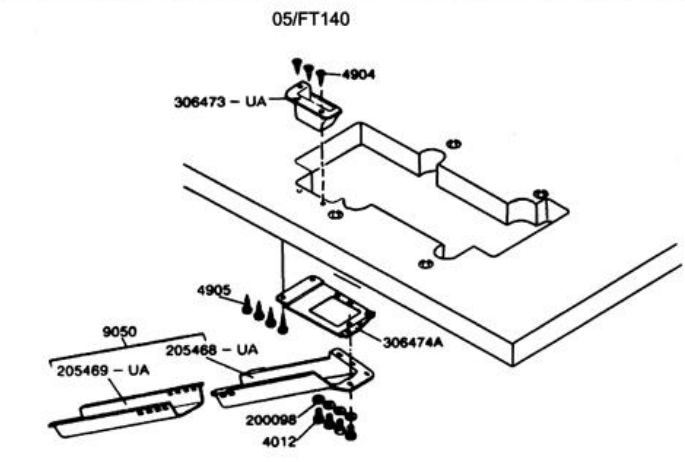
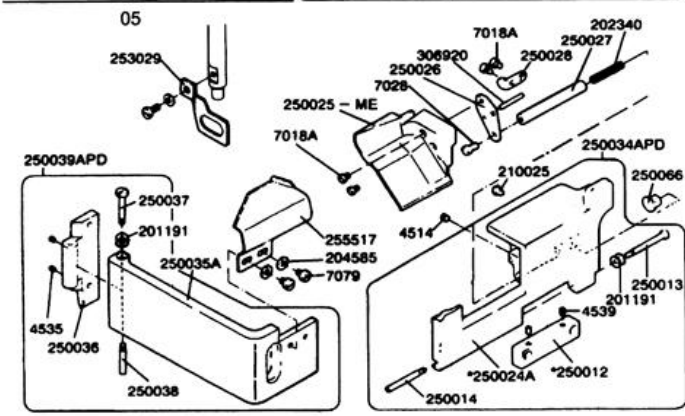
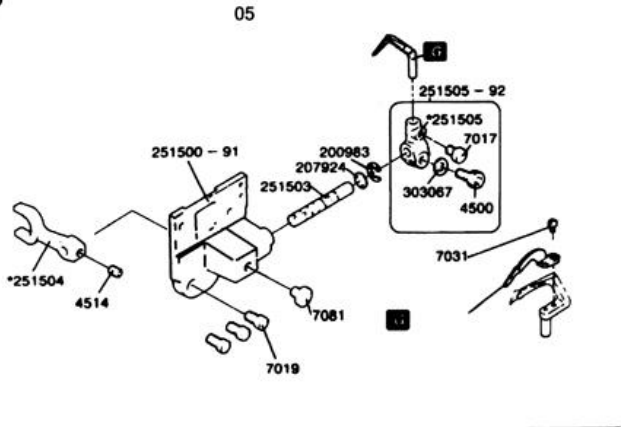

27

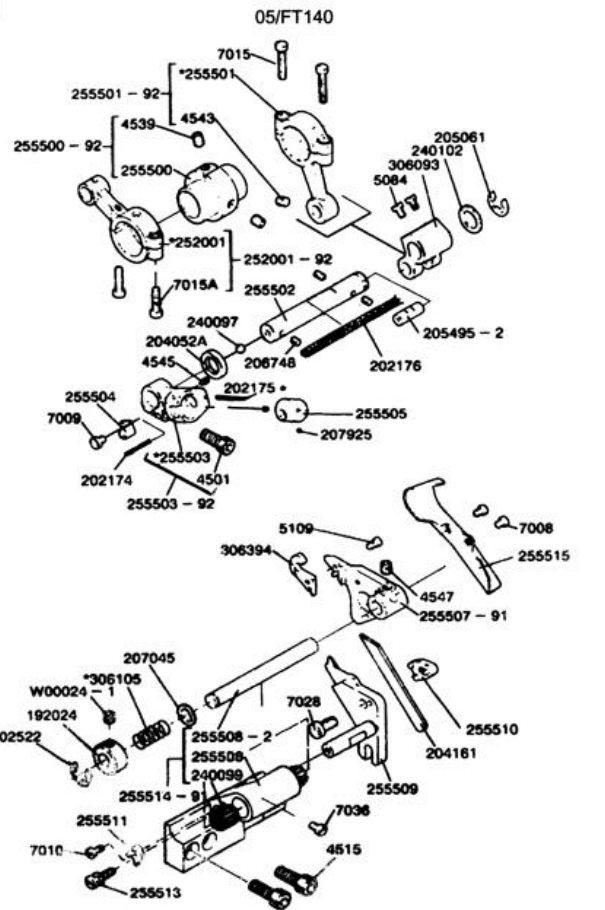

28

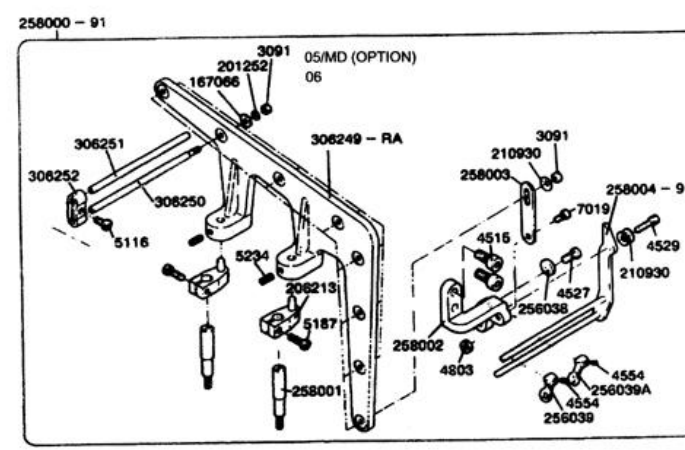
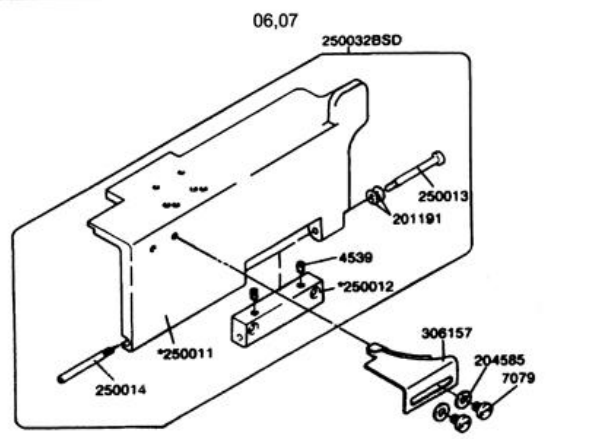

306469A9S

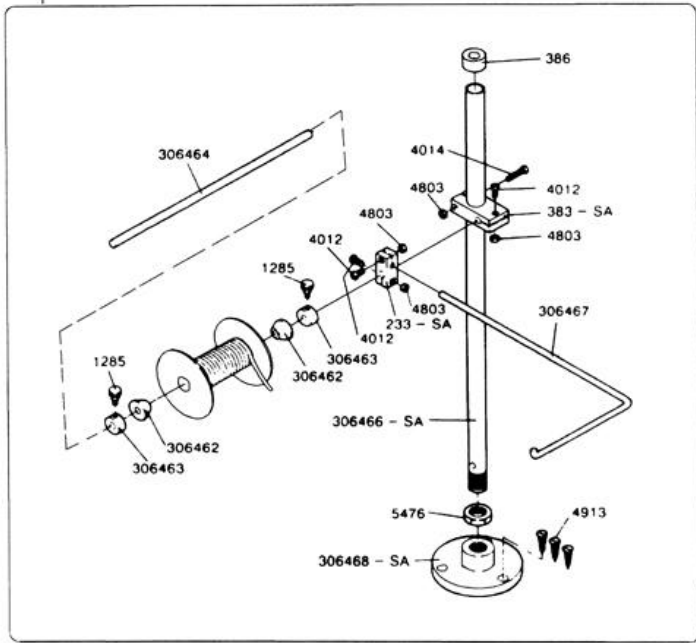

500-05 MD(OPTION)

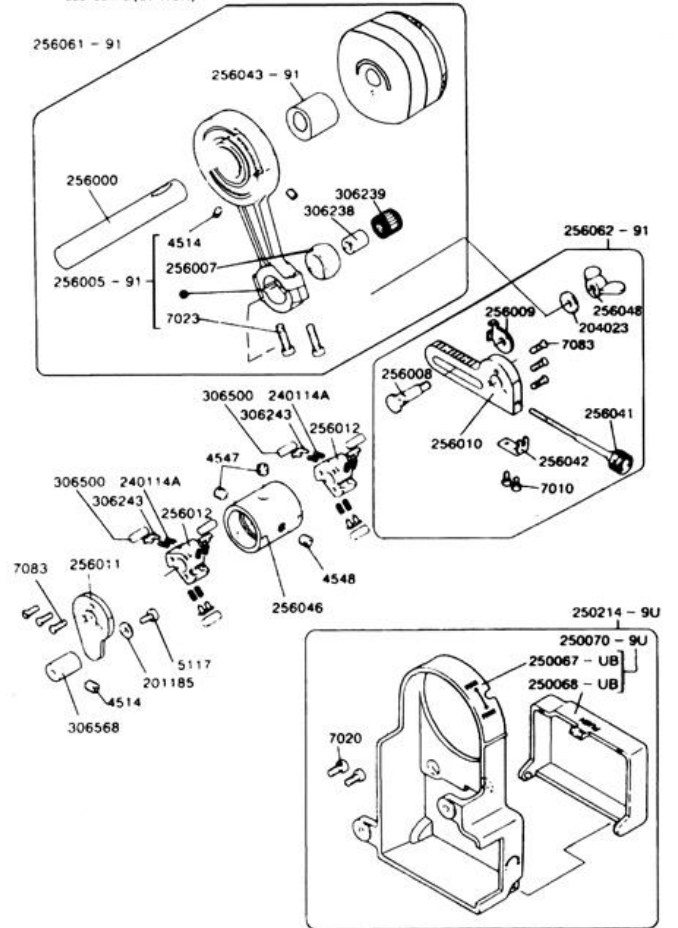

500-05MD(OPTION)

256064-9S

256065-91

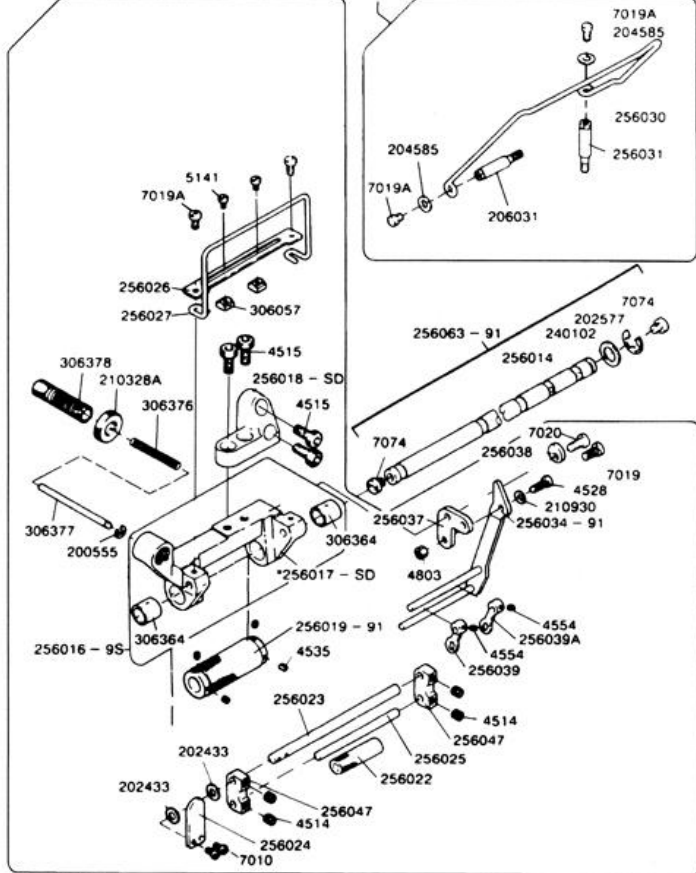

*(not for sale.)

(Standard)

- For light weight fabric 257571
- For heavy weight fabric 257571 (Put in accessory)

500-08A

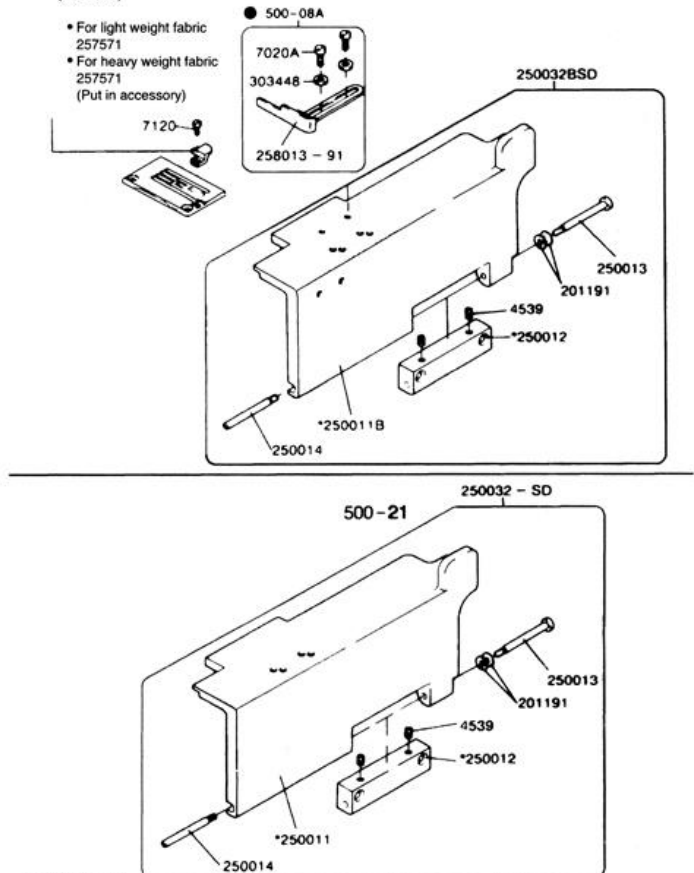
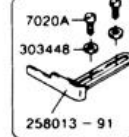

*(not for sale.)

33Please confirm the correct part by the gauge parts lists
500-21

CRANKSTAFF MECHANISM

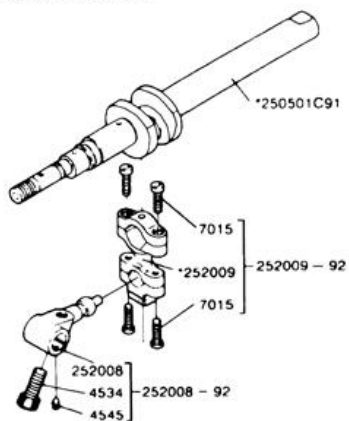

ARM SHAFT MECHANISM

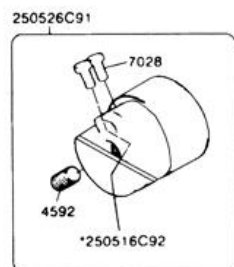
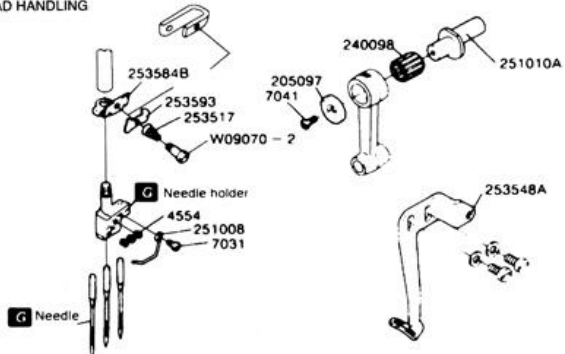
NEEDLE-SPREADER
THREAD HANDLING

*(not for sale.)

34

500-21

LOOPER MECHANISM

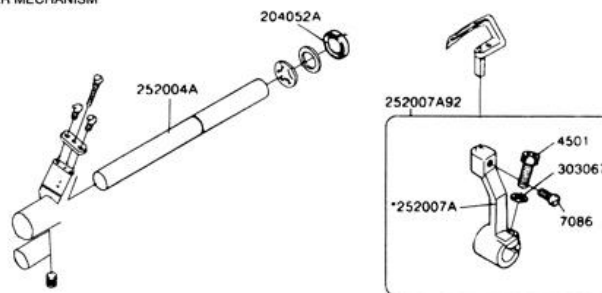

FEED MECHANISM

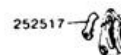

LUBRICATION MECHANISM

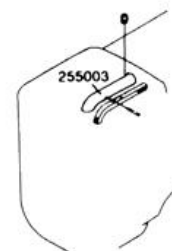

*(not for sale.)

35Please confirm the correct part by the gauge parts lists
500-84

250032 - SD

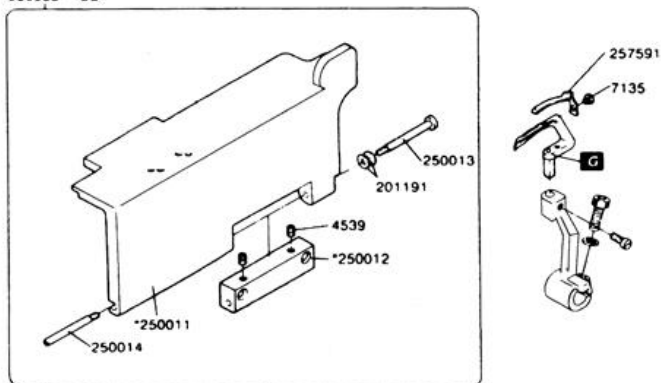

254023H9U

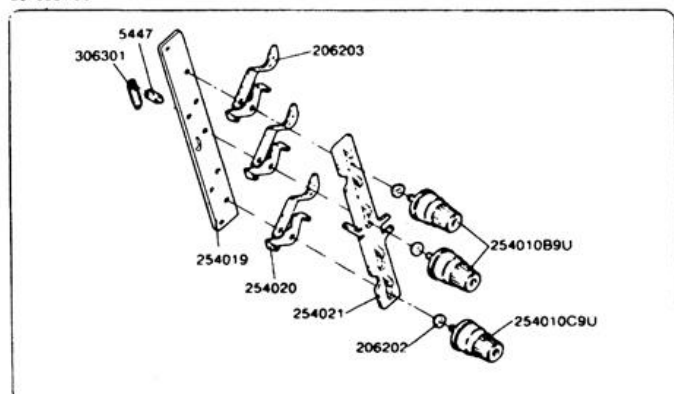

*(not for sale.)



形式 MACHINE TYPE /SECC.	缝样 GAUGE	针留 NEEDLE HOLDER	针板 NEEDLE PLATE	主送布牙 MAIN FEED DOG	差动送布牙 DIFF. FEED DOG	压脚 PRESSER FOOT	弯杆 LOOPER	护针(前) NEEDLE GUARD FRONT	护针(后) NEEDLE GUARD REAR	喂针 SPREADER	针 NEEDLE	
500-01CA 500-01CA/M	224	257517-24	257515A24	257206-16F	257258-16F	257460-24	257550E91	257553	257551B	25756S	UY128GAS #9	
	232	" 32	" 32			" 32						
	240	" 40	" 40			" 40						
	248	" 48	" 48			" 48						
	256	" 56	257517A56	257207-16F	257058-16F	" 56	257550-91					
	264	" 64	" 64	" 64								
	348	257518-48	257516A48	257206-16F	257258-16F	257461-48						257550E91
	356	" 56	257518A56	257207-16F	257259-16F	" 56						257550-91
364	" 64	" 64	" 64	" 64	" 64	257550-91	UY128GAS #10					
500-01CB 500-01CB/M	224	257517-24	257515B24	257206-16F	257258-16F	257460-24	257550E91	257553	257551B	25756S	UY128GAS #9	
	232	" 32	" 32			" 32						
	240	" 40	" 40			" 40						
	248	" 48	" 48			" 48						
	256	" 56	257517B56	257207-16F	257259-16F	" 56	257550-91					
	264	" 64	" 64	" 64								
	348	257518-48	257516B48	257206-16F	257258-16F	257461-48						257550E91
	356	" 56	257518B56	257207-16F	257259-16F	" 56						257550-91
364	" 64	" 64	" 64	" 64	" 64	257550-91	UY128GAS #10					
500-01CC 500-01CC/M	224	257517-24	257515C24	257206-16F	257258-16F	257460-24	257550E91	257553	257551B	25756S	UY128GAS #9	
	232	" 32	" 32			" 32						
	240	" 40	" 40			" 40						
	248	" 48	" 48			" 48						
	256	" 56	257517C56	257207-16F	257259-16F	" 56	257550-91					
	264	" 64	" 64	" 64								
	348	257518-48	257516C48	257206-16F	257258-16F	257461-48						257550E91
	356	" 56	257518C56	257207-16F	257259-16F	" 56						257550-91
364	" 64	" 64	" 64	" 64	" 64	257550-91	UY128GAS #10					
500-010DB 500-010DB/M	460	257513-60	257020-60	25723A-16F	257258-16F	257491-60	257550C91	257553	25755A	25756S	SM 1014B #3	
500-01GB 500-01GB/M	356	257518-56	257018B56	257207-16F	257259-16F	257472-56	257550-91	257553	257551B	25756S	UY128GAS #10	
364	" 64	" 64	" 64	" 64	" 64							



形式 MACHINE TYPE /SECC.	缝样 GAUGE	针留 NEEDLE HOLDER	针板 NEEDLE PLATE	主送布牙 MAIN FEED DOG	差动送布牙 DIFF. FEED DOG	压脚 PRESSER FOOT	弯杆 LOOPER	护针(前) NEEDLE GUARD FRONT	护针(后) NEEDLE GUARD REAR	喂针 SPREADER	针 NEEDLE		
500-02BA 500-02BA/M	224	257517-24	257029A24	257214-16F	257280-16F	257317A24	257550E91	257553	257551B	25756S	UY128GAS #9		
	232	" 32	" 32			" 32							
	240	" 40	257030A40			257215-16F	257281-16F					257318A40	257550-91
	248	" 48	" 48			" 48							
	256	" 56	257032A56	257216-16F	257282-16F	257319A56							
	264	" 64	" 64	" 64									
	348	257518-48	257031A48	257215-16F	257281-16F	257320A48	257550E91						
	356	" 56	257033A56	257216-16F	257282-16F	257321A56	257550-91						
364	" 64	" 64	" 64	" 64									
500-02BB 500-02BB/M	224	257517-24	257029B24	257214-16F	257280-16F	257317A24	257550E91	257553	257551B	25756S	UY128GAS #9		
	232	" 32	" 32			" 32							
	240	" 40	257030B40			257215-16F	257281-16F					257318A40	257550-91
	248	" 48	" 48			" 48							
	256	" 56	257032B56	257216-16F	257282-16F	257319A56							
	264	" 64	" 64	" 64									
	348	257518-48	257031B48	257215-16F	257281-16F	257320A48	257550E91						
	356	" 56	257033B56	257216-16F	257282-16F	257321A56	257550-91						
364	" 64	" 64	" 64	" 64									
500-02BC 500-02BC/M	224	257517-24	257029C24	257214-16F	257280-16F	257317A24	257550E91	257553	257551B	25756S	UY128GAS #9		
	232	" 32	" 32			" 32							
	240	" 40	257030C40			257215-16F	257281-16F					257318A40	257550-91
	248	" 48	" 48			" 48							
	256	" 56	257032C56	257216-16F	257282-16F	257319A56							
	264	" 64	" 64	" 64									
	348	257518-48	257031C48	257215-16F	257281-16F	257320A48	257550E91						
	356	" 56	257033C56	257216-16F	257282-16F	257321A56	257550-91						
364	" 64	" 64	" 64	" 64									



形式 MACHINE TYPE /SECC.	缝样 GAUGE	针留 NEEDLE HOLDER	针板 NEEDLE PLATE	主送布牙 MAIN FEED DOG	差动送布牙 DIFF. FEED DOG	压脚 PRESSER FOOT	弯杆 LOOPER	护针(前) NEEDLE GUARD FRONT	护针(后) NEEDLE GUARD REAR	喂针 SPREADER	针 NEEDLE
500-02SA 500-02SA/M	224	257517-24	257023A24	257208-16F	257261-16F	257350-24	257350E91	257553	257551B	25756S	UY128GAS #3
	232	" 32	" 32			" 32					
	240	" 40	257024A40	257210-16F	257202-16F	257351-40					
	248	" 48	" 48			" 48	257550-91				
	256	" 56	257041A56	257210-16F	257262-16F	257358-56					
	264	" 64	" 64			" 64					
	348	257518-48	257040A48	257209-16F	257261-16F	257359-48	257550E91				
	356	" 56	257025A56	257210-16F	257262-16F	257352-56	257550-91				
364	" 64	" 64			" 64						
500-02SB 500-02SB/M	224	257517-24	257023B24	257208-16F	257260-16F	257350-24	257350E91	257553	257551B	25756S	UY128GAS #9
	232	" 32	" 32			" 32					
	240	" 40	257024B40	257209-16F	257261-16F	257351-40					
	248	" 48	" 48			" 48	257550-91				
	256	" 56	257040B56	257210-16F	257262-16F	257358-56					
	264	" 64	" 64			" 64					
	348	257518-48	257041B48	257209-16F	257261-16F	257359-48	257550E91				
	356	" 56	257025B56	257210-16F	257262-16F	257352-56	257550-91				
364	" 64	" 64			" 64						
500-02SC 500-02SC/M	224	257517-24	257023C24	257208-16F	257260-16F	257350-24	257550E91	257553	257551B	25756S	UY128GAS #9
	232	" 32	" 32			" 32					
	240	" 40	257024C40	257209-16F	257261-16F	257351-40					
	248	" 48	" 48			" 48	257550-91				
	256	" 56	257041C56	257210-16F	257262-16F	257358-56					
	264	" 64	" 64			" 64					
	348	257518-48	257040C48	257209-16F	257261-16F	257359-48	257550E91				
	356	" 56	257025C56	257210-16F	257262-16F	257352-56	257550-91				
364	" 64	" 64			" 64						
500-02CA 500-02CA/M	232	257139A32	257139A32	259123-16F	257260-16F	2572448-32	257550-91	257553	257551B	25756S	YU128GAS #10
500-02CB 500-02CB/M	240	257140A40	257140A40	259124-16F	257262-16F	257449-40	257550-91	257553	257551B	25756S	YU128GAS #10
500-02CC 500-02CC/M	232	257139B32	257139A32	259123-16F	257260-16F	2572448-32	257550-91	257553	257551B	25756S	YU128GAS #10
500-02DB 500-02DB/M	240	257140B40	257140A40	259124-16F	257261-16F	257449-40	257550-91	257553	257551B	25756S	YU128GAS #10
500-02CC 500-02CC/M	232	257139C32	257139A32	259123-16F	257260-16F	2572448-32	257550-91	257553	257551B	25756S	YU128GAS #10
500-02DB 500-02DB/M	240	257140C40	257140A40	259124-16F	257261-16F	257449-40	257550-91	257553	257551B	25756S	YU128GAS #10
500-02DB 500-02DB/M	232	257157B32	257157B32	259128-16F	259234-16F	257449-34	257550-91	257553	257551B	25756S	YU128GAS #10

缝纫组合件 表 (4)

GAUGE PARTS LIST (4)



形式 MACHINE TYPE /SECC.	缝样 GAUGE	针留 NEEDLE HOLDER	针板 NEEDLE PLATE	主送布牙 MAIN FEED DOG	差动送布牙 DIFF. FEED DOG	压脚 PRESSER FOOT	弯杆 LOOPER	护针(前) NEEDLE GUARD FRONT	护针(后) NEEDLE GUARD REAR	喂针 SPREADER	针 NEEDLE
500-02BA 500-02BA/M	240	257517-40	257087B40	257206-16F	259200-16F	257467-40		257553	257551B	25756S	UY128GAS #9
	248	" 48	" 48			" 48					
	256	" 56	257089B56	257207-16F	259253-16F	" 56	257550-91				
	264	" 64	" 64			" 64					
	348	257518-48	257088B48	257206-16F	259200-16F	257468-48	257550E91				
	356	" 56	257090B56	257207-16F	259253-16F	" 56	257550-91				
364	" 64	" 64			" 64						
500-02BB 500-02BB/M	240	257517-40	257087B40	257206-16F	259200-16F	257467-40		257553	257551B	25756S	UY128GAS #9
	248	" 48	" 48			" 48					
	256	" 56	257089B56	257207-16F	259253-16F	" 56					
	264	" 64	" 64			" 64					
	348	257518-48	257088B48	257206-16F	259200-16F	257468-48	257550E91				
	356	" 56	257090B56	257207-16F	259253-16F	" 56	257550-91				
364	" 64	" 64			" 64						
500-02BC 500-02BC/M	240	257517-40	257091B40	257206-16F	259201-16F	257467-40		257553	257551B	25756S	UY128GAS #9
	248	" 48	" 48			" 48	257550-91				
	256	" 56	257093B56	257207-16F	259254-16F	" 56					
	264	" 64	" 64			" 64					
	348	257518-48	257092B48	257206-16F	259201-16F	257468-48	257750E91				
	356	" 56	257094B56	257207-16F	259254-16F	" 56	257550-91				
364	" 64	" 64			" 64						
500-02BC 500-02BC/M	240	257517-40	257091C40	257206-16F	259201-16F	257467-40		257553	257551B	25756S	UY128GAS #9
	248	" 48	" 48			" 48	257550-91				
	256	" 56	257093C56	257207-16F	259254-16F	" 56					
	264	" 64	" 64			" 64					
	348	257518-48	257092C48	257206-16F	259200-16F	257468-48	257550E91				
	356	" 56	257094C56	257207-16F	259254-16F	" 56	257550-91				
364	" 64	" 64			" 64						



形式 MACHINE TYPE /SEEC.	缝样 GAUGE	针留 NEEDLE HOLDER	针板 NEEDLE PLATE	主送布牙 MAIN FEED DOG	差动送布牙 DIFF. FEED DOG	压脚 PRESSER FOOT	弯杆 LOOPER	护针(前) NEEDLE GUARD FRONT	护针(后) NEEDLE GUARD REAR	喂针 SPREADER	针 NEEDLE
500-05BA 500-05BA/M	224	257517-24	257049A24	257220-16F	257266-16F	257327A24	257550E91	257553	257551B	25756S	UY128GAS #3
	232	" 32	" 32			" 32					
	240	" 40	257050A40	257221-16F	257267-16F	257328A40					
	248	" 48	" 48			" 48	257550-91				
	256	" 56	257052A56	257222-16F	257268-16F	257329A56					
	264	" 64	" 64			" 64					
	348	257518-48	257051A48	257221-16F	257267-16F	257330A48	257550E91				
	356	" 56	257053A56	257222-16F	257268-16F	257331A56	257550-91				
364	" 64	" 64			" 64						
500-05BB 500-05BB/M	224	257517-24	257049A24	257220-16F	257266-16F	257327A24	257550E91	257553	257551B	25756S	UY128GAS #9
	232	" 32	" 32			" 32					
	240	" 40	257050A40	257221-16F	257267-16F	257328A40					
	248	" 48	" 48			" 48	257550-91				
	256	" 56	257052A56	257222-16F	257268-16F	257329A56					
	264	" 64	" 64			" 64					
	348	257518-48	257051A48	257221-16F	257267-16F	257330A48	257550E91				
	356	" 56	257053A56	257222-16F	257268-16F	257331A56	257550-91				
364	" 64	" 64			" 64						
500-05SA 500-05SA/M	224	257517-24	257049A24	257220-16F	257266-16F	257327A24	257550E91	257553	257551B	25756S	UY128GAS #9
	232	" 32	" 32			" 32					
	240	" 40	257050A40	257221-16F	257267-16F	257328A40					
	248	" 48	" 48			" 48	257550-91				
	256	" 56	257052A56	257222-16F	257268-16F	257329A56					
	264	" 64	" 64			" 64					
	348	257518-48	257051A48	257221-16F	257267-16F	257330A48	257550E91				
	356	" 56	257053A56	257222-16F	257268-16F	257331A56	257550-91				
364	" 64	" 64			" 64						
500-05SB 500-05SB/M	224	257517-24	257049A24	257220-16F	257266-16F	257327A24	257550E91	257553	257551B	25756S	UY128GAS #9
	232	" 32	" 32			" 32					
	240	" 40	257050A40	257221-16F	257267-16F	257328A40					
	248	" 48	" 48			" 48	257550-91				
	256	" 56	257052A56	257222-16F	257268-16F	257329A56					
	264	" 64	" 64			" 64					
	348	257518-48	257051A48	257221-16F	257267-16F	257330A48	257550E91				
	356	" 56	257053A56	257222-16F	257268-16F	257331A56	257550-91				
364	" 64	" 64			" 64						



形式 MACHINE TYPE /SEEC.	缝样 GAUGE	针留 NEEDLE HOLDER	针板 NEEDLE PLATE	主送布牙 MAIN FEED DOG	差动送布牙 DIFF. FEED DOG	压脚 PRESSER FOOT	弯杆 LOOPER	护针(前) NEEDLE GUARD FRONT	护针(后) NEEDLE GUARD REAR	喂针 SPREADER	针 NEEDLE
500-05CA 500-05CA/M	224	257517-24	257049A24	257220-16F	257266-16F	257327A24	257550E91	257553	257551B	25756S	UY128GAS #9
	232	" 32	" 32			" 32					
	240	" 40	257050A40	257221-16F	257267-16F	257328A40					
	248	" 48	" 48			" 48	257550-91				
	256	" 56	257052A56	257222-16F	257268-16F	257329A56					
	264	" 64	" 64			" 64					
	348	257518-48	257051A48	257221-16F	257267-16F	257330A48	257550E91				
	356	" 56	257053A56	257222-16F	257268-16F	257331A56	257550-91				
364	" 64	" 64			" 64						
500-05CB 500-05CB/M	224	257517-24	257049A24	257220-16F	257266-16F	257327A24	257550E91	257553	257551B	25756S	UY128GAS #9
	232	" 32	" 32			" 32					
	240	" 40	257050A40	257221-16F	257267-16F	257328A40					
	248	" 48	" 48			" 48	257550-91				
	256	" 56	257052A56	257222-16F	257268-16F	257329A56					
	264	" 64	" 64			" 64					
	348	257518-48	257051A48	257221-16F	257267-16F	257330A48	257550E91				
	356	" 56	257053A56	257222-16F	257268-16F	257331A56	257550-91				
364	" 64	" 64			" 64						



形式 MACHINE TYPE /SEEC.	缝样 GAUGE	针留 NEEDLE HOLDER	针板 NEEDLE PLATE	主送布牙 MAIN FEED DOG	差动送布牙 DIFF. FEED DOG	压脚 PRESSER FOOT	弯杆 LOOPER	护针(前) NEEDLE GUARD FRONT	护针(后) NEEDLE GUARD REAR	喂针 SPREADER	针 NEEDLE	
500-06BA 500-06BA/M 500-07BA 500-07BA/M	232	257517-32	257044A32	257214-16F	257260-16F	257337A32	257550-91	257553	257551B	25756S	UY128GAS #9	
	240	" 40	257045A40	257215-16F	257261-16F	257338A40						
	248	" 48	" 48			" 48						
	256	" 56	257047A56	257216-16F	257262-16F	257339A56						
	264	" 64	" 64			" 64						
	348	257518-48	257046A48	257215-16F	257261-16F	257339A48						257550E91
	356	" 56	257048A56	257216-16F	257262-16F	257341A56						257550-91
364	" 64	" 64	" 64									
500-06BB 500-06BB/M 500-07BB 500-07BB/M	232	257517-32	257044B32	257214-16F	257260-16F	257337A32	257550-91	257553	257551B	25756S	UY128GAS #9	
	240	" 40	257045B40	257215-16F	257261-16F	257338A40						
	248	" 48	" 48			" 48						
	256	" 56	257047B56	257216-16F	257262-16F	257339A56						
	264	" 64	" 64			" 64						
	348	257518-48	257046B48	257215-16F	257261-16F	257339A48						257550E91
	356	" 56	257048B56	257216-16F	257262-16F	257341A56						257550-91
364	" 64	" 64	" 64									
500-08AB 500-08AB/M	240	257517-40	257084B40	257206-16F	259209-16F	257480-40	257550-91	257553	257551B	25756S	UY128GAS #9	
	248	" 48	" 48			" 48						
	356	257518-56	257095B56	257207-16F	259210-16F	257461-56						
	364	" 64	" 64			" 64						
500-08AC 500-08AC/M	240	257517-40	257084C40	257206-16F	259209-16F	257160-48	257550-91	257553	257551B	25756S	UY128GAS #9	
	248	" 48	" 48			" 48						
	256	257518-56	257095C56	257207-16F	259210-16F	257461-56						
	364	" 64	" 64			" 64						



形式 MACHINE TYPE /SEEC.	缝样 GAUGE	针留 NEEDLE HOLDER	针板 NEEDLE PLATE	主送布牙 MAIN FEED DOG	差动送布牙 DIFF. FEED DOG	压脚 PRESSER FOOT	弯杆 LOOPER	护针(前) NEEDLE GUARD FRONT	护针(后) NEEDLE GUARD REAR	喂针 SPREADER	针 NEEDLE
500-21BA 500-21BA/M	356	257501C58	257022A56	257207-16F	257259-16F	257466-56	257550A91	257553	257551B	25756S	UY128GAS #10
	364	" 64	" 64			" 64					
500-21BB 500-21BB/M	356	257501C56	257022B56	257207-16F	257259-16F	257466-56	257550A-91	257553	257551B	25756S	UY128GAS #10
	364	" 64	" 64			" 64					
50082AB/M	224	257517-24	257119-24	257206-16F	257223-16F	257460-24	257550E91	257553	257551B	25756S	UY128GAS #10
	240	" 40	" 40			" 40					
	248	" 48	" 48			" 48					
	356	257518-56	257120-56	257207-16F	257224-16F	257461-56					
	364	" 64	" 64			" 64					

500N系列子型号规格表

500N系列



用途	子型号	针数 (根)	针数 (根)	针距(mm)	最大针 脚长 (mm)	差动比	压脚抬升量 (mm)	最高旋转数 (rpm)	备考
基本缝纫用	500-01CB	2 3	4 5	2.4·3.2·4·4.8·5.6·6.4 4.8·5.6·6.4	4.4	0.5~1.3	6.3 5	6,000	
松紧带滚边用	500-02BB	2 3	4 5	2.4·3.2·4·4.8·5.6·6.4 4.8·5.6·6.4	4.4	0.5~1.3	6.3 5	6,000	
绷盖缝用	500-03DB	2 3	4 5	4·4.8·5.6·6.4 4.8·5.6·6.4	4.4	0.5~1.3	6.3 5	6,000	
	500-03EB	2 3	4 5	4·4.8·5.6·6.4 4.8·5.6·6.4	4.4	0.5~1.3	6.3 5	6,000	
缝花边松紧带用	500-05CB	2 3	4 5	2.4·3.2·4·4.8·5.6·6.4 4.8·5.6·6.4	4.4	0.5~1	6.3 5	5,500 (MMD 5,000)	
	500-07BB	2 3	4 5	3.2·4·4.8·5.6·6.4 4.8·5.6·6.4	4.4	0.5~1.3	6.3 5	5,000	
缝花边用	500-06BB	2 3	4 5	3.2·4·4.8·5.6·6.4 4.8·5.6·6.4	4.4	0.5~1.3	6.3 5	6,000	
下摆折缝用	500-08AB	2 3	4 5	4·4.8 5.6·6.4	4.4	0.5~1.3	6.3 5	6,000	

※差动比使用1:1.3以上时, 请将主送布牙运动量设定在3.2mm以下、

针脚形式	602, 605
使用的针	UY128GAS #9S UY128GAS #10S
整机尺寸(WxDxH)	W: 495mm D: 2801mm H: 414mm

干燥时重量	41.5Kg
总重量	47.5Kg UY128GAS #10S
噪音值	n=5,400rpm: Lpas82.0dB DIN 45635 48A-1 遵循